

# Non-Penetrative Flush Installation Guide

Code-Compliant Planning and Installation Guide V 5.2  
Complying with AS/NZS 1170.2:2021

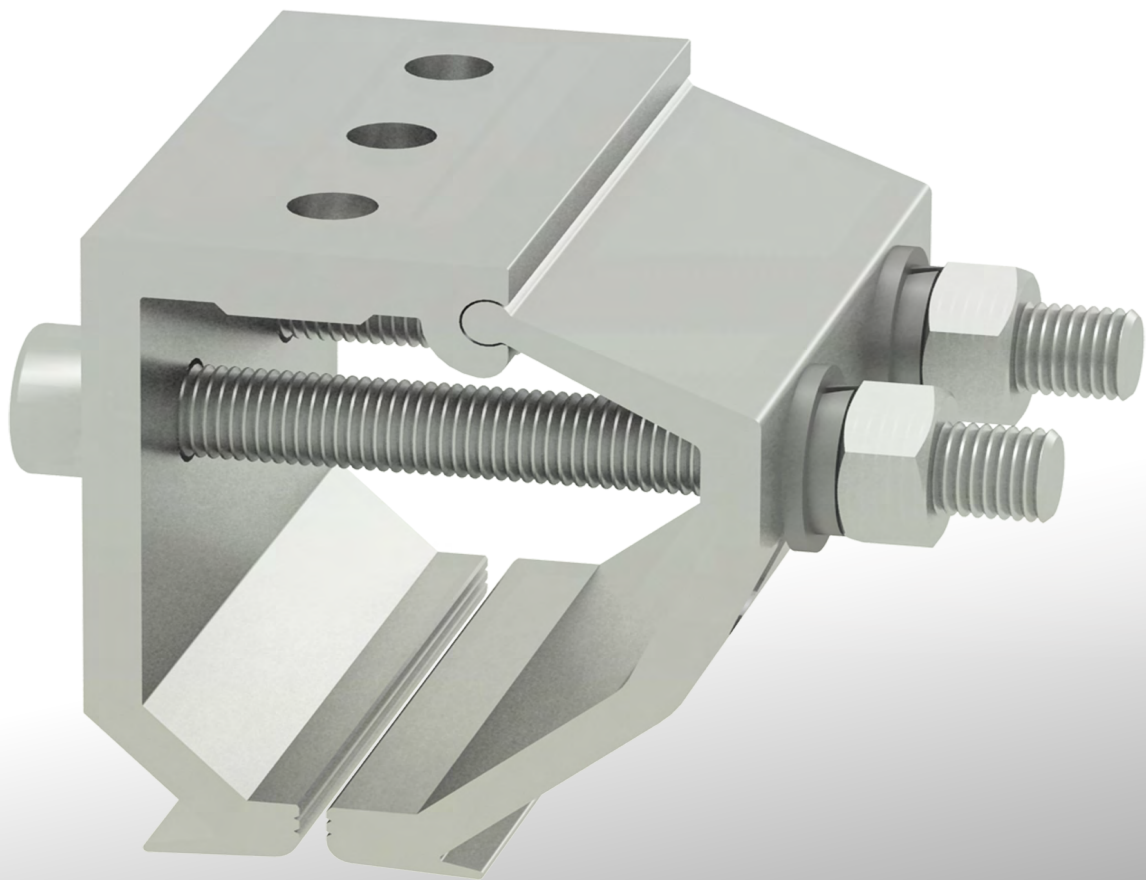

# Introduction

The Clenergy PVezRack® SolarRoof has been developed as a universal PV-mounting system for roof-mounting on pitched and flat roofs. The use of patented aluminium base rails and Z-Module technology enables fast and easy installation.

Please review this manual thoroughly before installing PVezRack® SolarRoof. This manual provides:

- 1) Supporting documentation for building permit applications relating to PVezRack® SolarRoof Universal PV Module Mounting System,
- 2) Planning and installation instructions.

## List of contents

Introduction	1
Planning	2
Tools & Component list	10
System Overview	12
Installation Instructions	15
Certification	19

The PVezRack® SolarRoof parts, when installed in accordance with this guide, will be structurally sound and will meet the AS/NZS 1170.2:2021 standard. During installation, and especially when working on the roof, please comply with the appropriate Occupational Health and Safety regulations. Please also pay attention to any other relevant State or Federal regulations. Please check that you are using the latest version of the Installation Manual, which you can do by contacting Clenergy Australia via email on [tech@clenergy.com.au](mailto:tech@clenergy.com.au), or contacting your local distributor in Australia.

### Product Warranty:

Please refer [PVezRack® Product Warranty](#) on our website.

### The installer is solely responsible for:

- Complying with all applicable local or national building codes, including any updates that may supersede this manual;
- Ensuring that PVezRack® and other products are appropriate for the particular installation and the installation environment;
- Using only PVezRack® parts and installer-supplied parts as specified by PVezRack® (substitution of parts may void the warranty and invalidate the letter of certification);
- Recycling: Recycle according to the local relative statute;
- Removal: Reverse installation process;
- Ensuring that there are no less than two professionals working on the panel installation;
- Ensuring the installation of related electrical equipment is performed by licenced electricians;
- Ensuring safe installation of all electrical aspects of the PV array. This includes adequate earth bonding of the PV array and PVezRack® SolarRoof components as required in AS/NZS 5033: 2021.
- Ensuring that the roof, its rafters/purlins, connections and other structural support members can support the array under building live load conditions;
- Verifying the compatibility of the installation considering preventing electrochemical corrosion between dissimilar metals. This may occur between structures and the building and also between structures, fasteners and PV modules, as detailed in AS/NZS 5033: 2021;
- Verifying atmospheric corrosivity zone of installation site by referring to AS 4312-2008 or consulting local construction business to determine appropriate products and installations.

# Planning

## Determine the type of concealed roof

The best way to identify the type of concealed roof installed is to check the label normally located underneath the roofing sheet. Otherwise, you can contact the builder or check the building plan to find out the exact type of the roofing sheet.

### Notes:

- 1) Use of the Clenergy Klip-lok brackets is accredited only on the roof sheet types listed below;
- 2) If the roof sheet type (brand and model) cannot be identified, it is recommended to undertake on-site pull-out capacity test;
- 3) Klip-lok bracket can be direct contact with the majority of roof sheet without use of stand-off material between bracket and roof sheet. Please verify the roof sheet material and its compatibility with bracket (material: anodized aluminium) from the roof sheet manufacturer or refer the Clenergy Technical Bulletin of Dissimilar Metals (available on request) for the details.
- 4) Roof testing of ER-I-34 was completed without using EPDM between roofing sheet and bracket, therefore the generic spacing information for ER-I-34 cannot be applied if EPDM or similar rubber is used between roofing sheet and bracket. In case EPDM or similar rubber is required under Klip-lok bracket for concealed roof installation, please use a different Klip-lok bracket (such as ER-I-09), if this is approved for your specific roofing sheet. An alternative option is to complete a site specific uplift test using ER-I-34 with EPDM based on which a project specific Engineering Certificate can be issued.

(1) Lysaght Klip Lok 700 Classic (Interface: ER-I-34, ER-I-09)

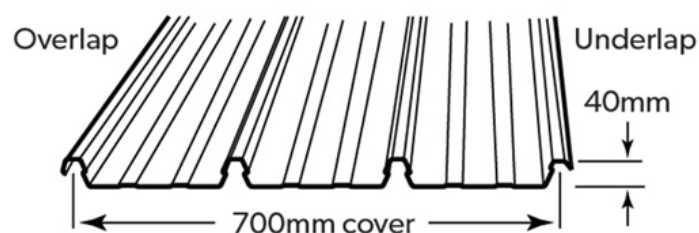

(2) Lysaght Klip-Lok 700 High Strength (Interface: ER-I-34, ER-I-09)

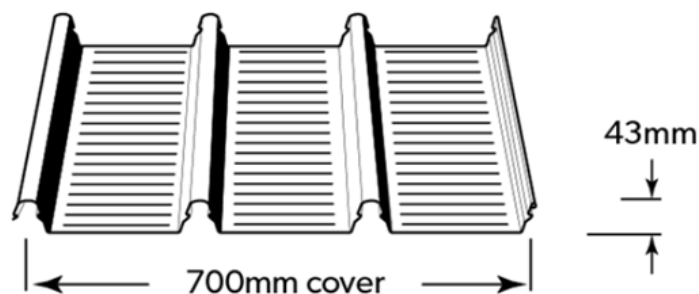

(3) Lysaught Klip-Lok 406 (Interface: ER-I-34, ER-I-32/AU)

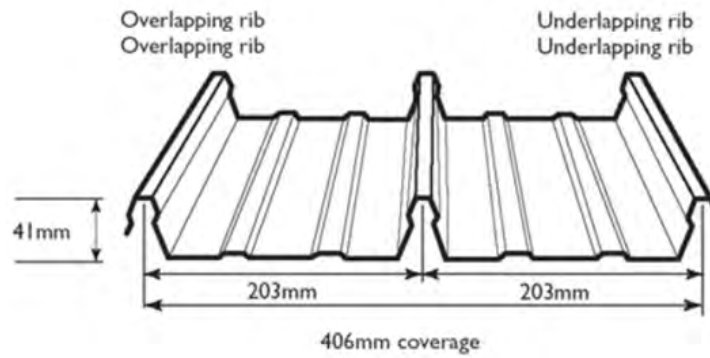

(4) Stramit Speed Deck Ultra (Interface: ER-I-34, ER-I-09)

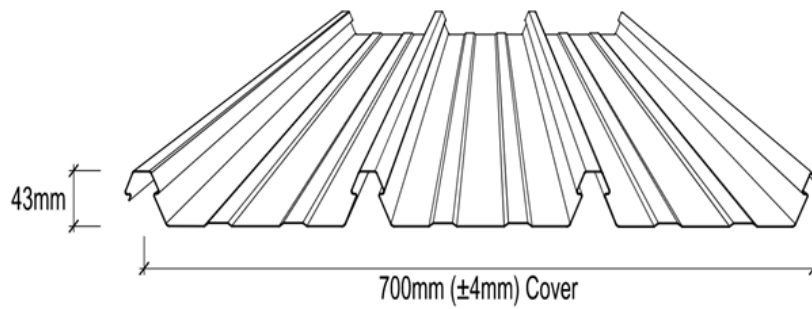

(5) Stramit Speed Deck 500 (Interface: ER-I-34, ER-I-09)

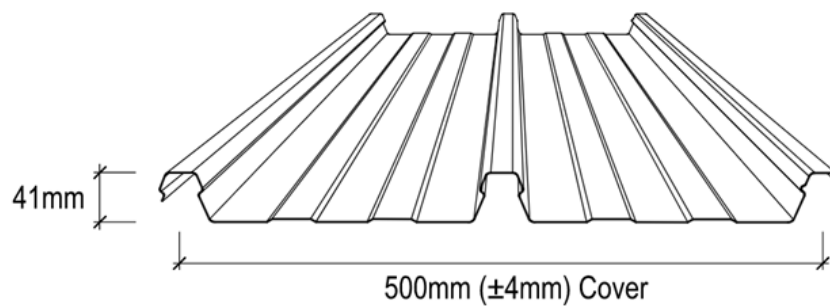

(6) Fielders Kingclip 700 (Interface: ER-I-34, ER-I-09)

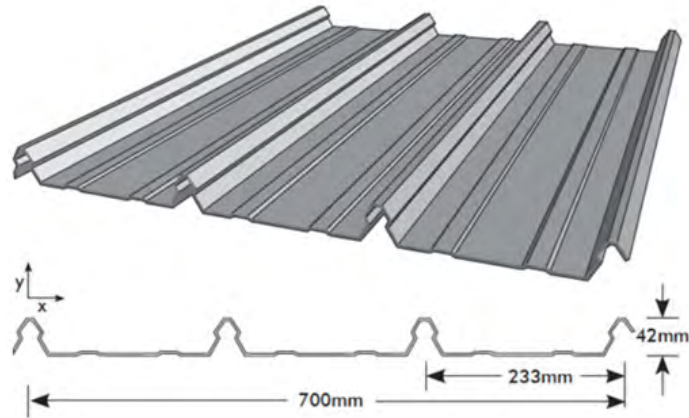

(7) Stratco Topdeck 700 (Interface: ER-I-34, ER-I-09)

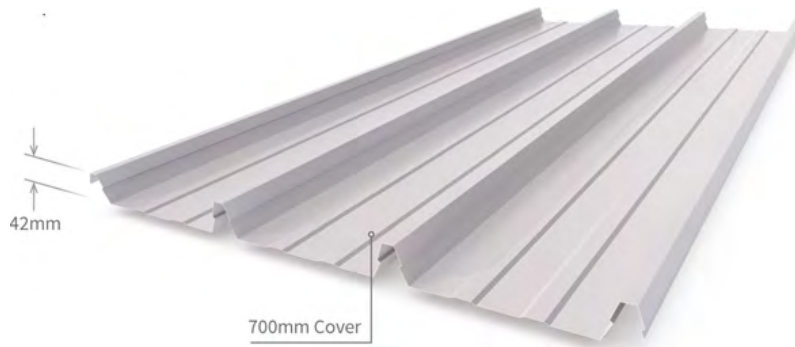

(8) Metroll Metlok 700 (Interface: ER-I-34, ER-I-09)

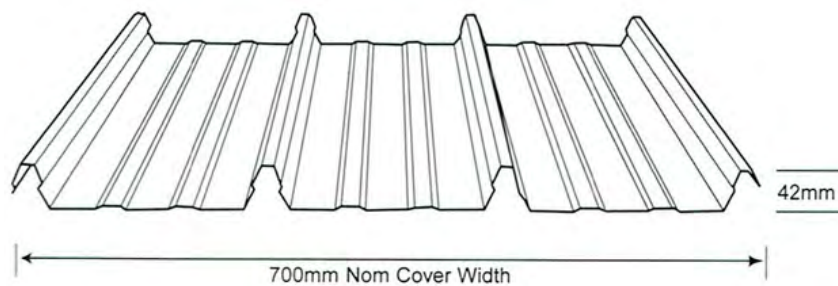

(9) Metroll Metlok 500 (Interface: ER-I-34)

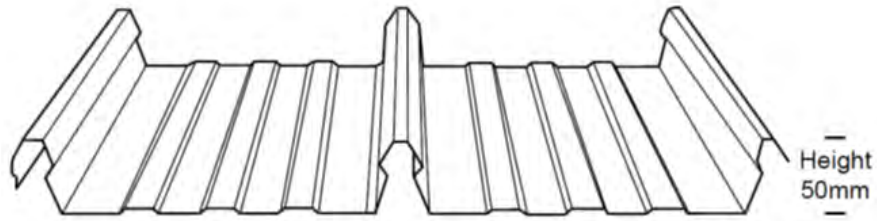

(10) Revolution Maxline 340 (Interface: ER-I-34)

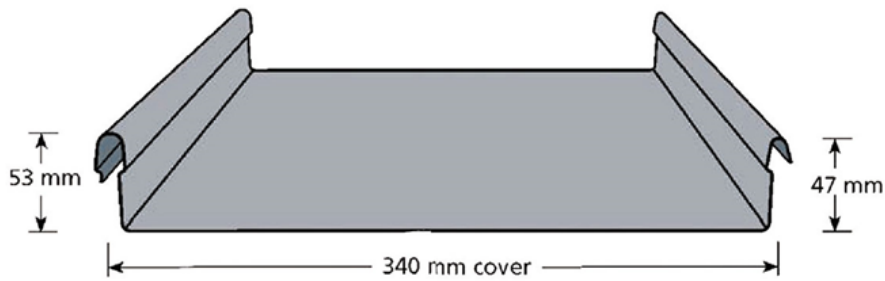

(11) Steeline Lokdek 680 (Interface: ER-I-34)

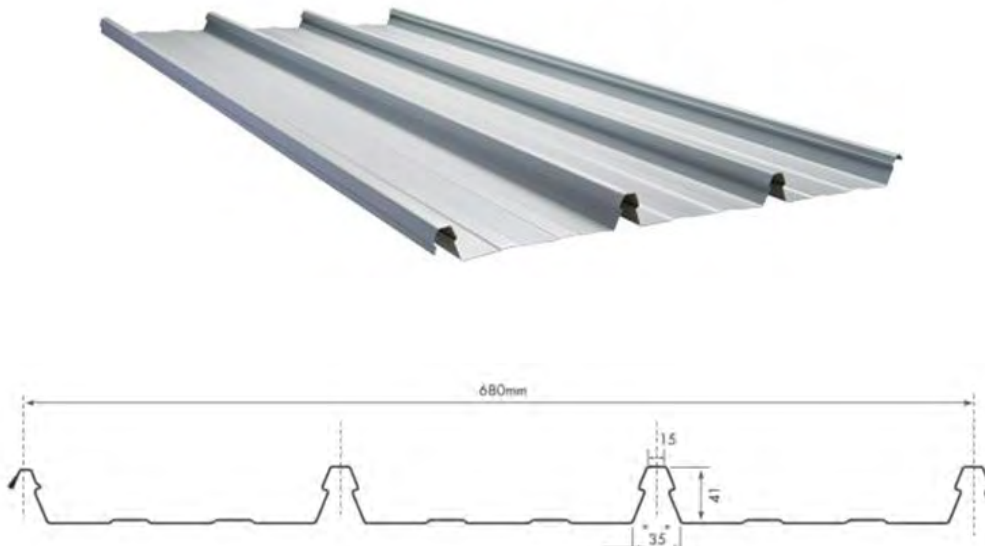

(12) Steeline Steel-Rib 500 (ST28) (Interface: ER-I-34)

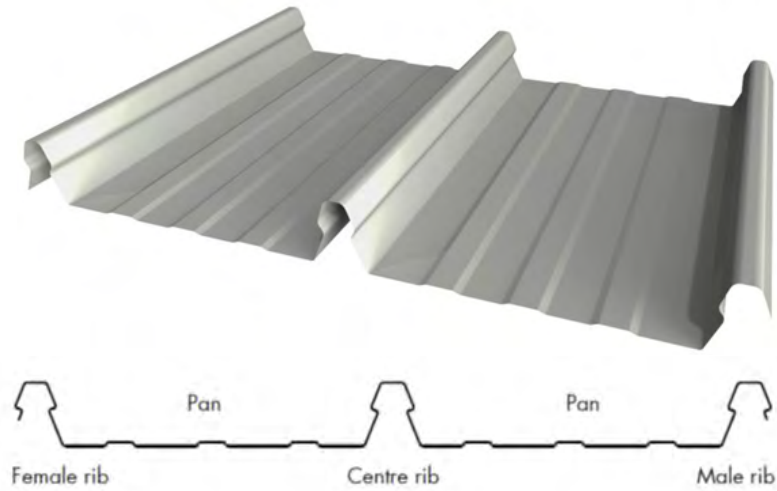

(13) Rev-Klip 700 (Interface: ER-I-34)

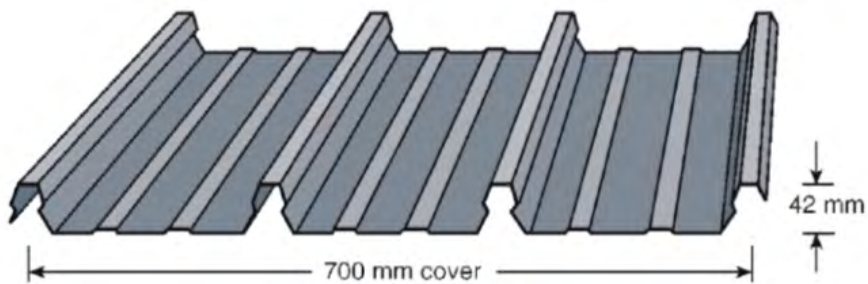

(14) Lysaght LongLine 305 (Interface: ER-I-34, ER-I-29/AU)

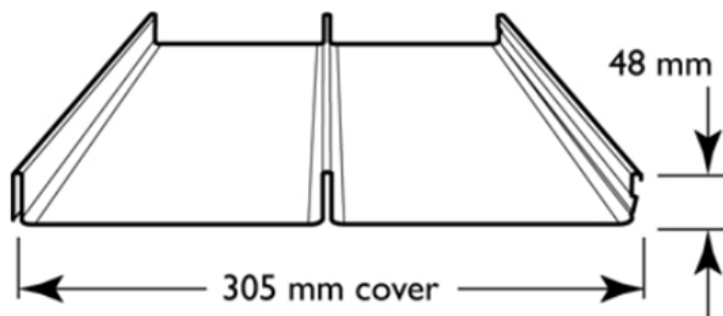

**Note:**

when using ER-I-34 for longline 305 roof sheet installation, please refer to generic note 3 in the engineering letter to apply for interface spacing reduction based on those for ER-I-29/AU.

## Determine the wind region of your installation site

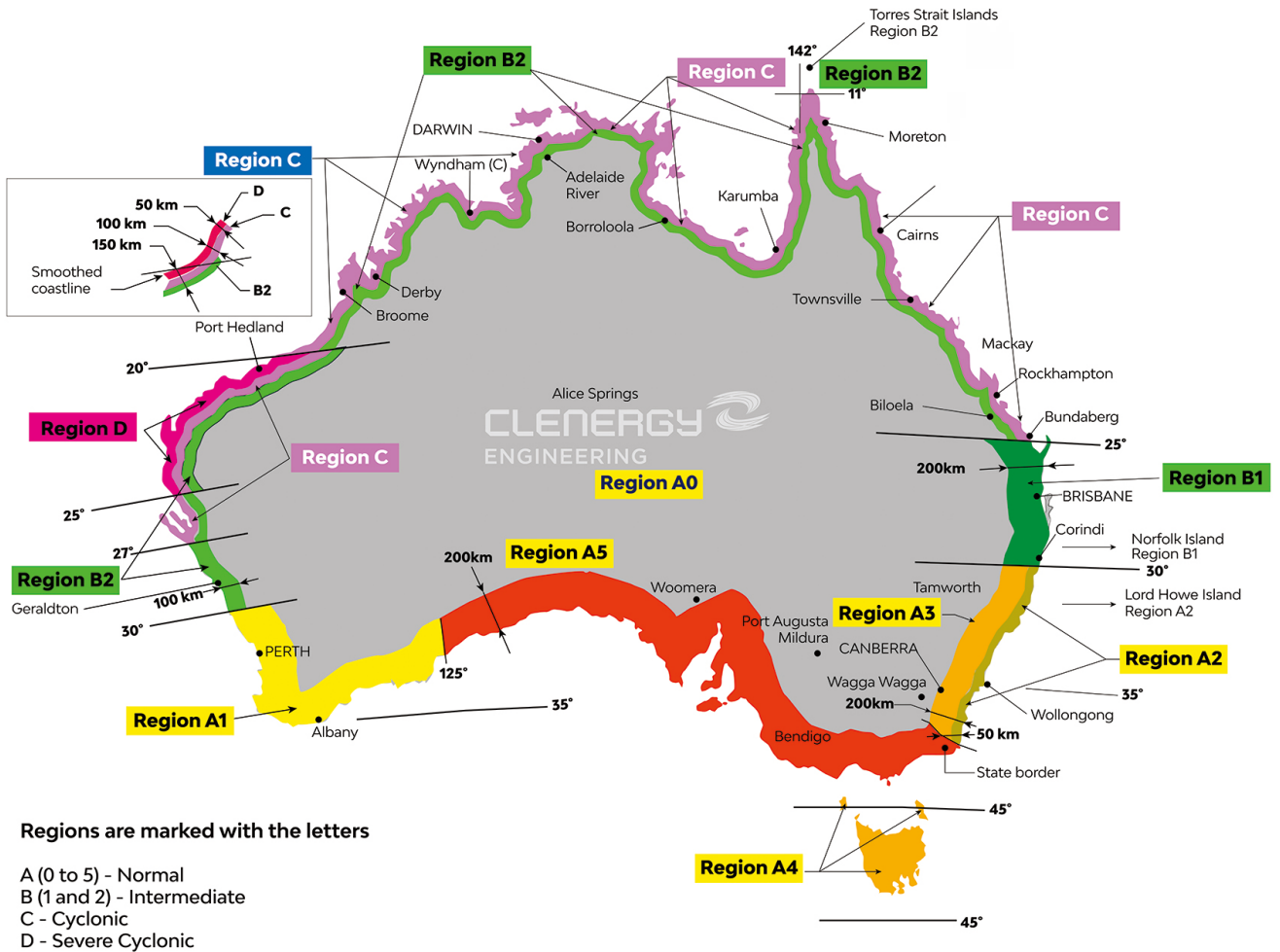

Wind Regions – Australia

Wind regions are pre-defined for the whole of Australia by the Australian Standard 1170.2:2021. Comparing to 1170.2:2011, 2021 version has a lot of changes in wind regions.

- Central Australia is now classified as Wind Region A0 and Terrain Classification 2 instead of Wind Region A4.
- Region A1, previously most of the South coast of Australia, now is divided into Regions A1 and A5.
- Tasmania is now Region A4.
- Region B has been divided into regions B1 and B2. This will affect installations in Northern NSW, Gold Coast, Brisbane, Sunshine Coast, and Gladstone.
- Region B1 was increased to include more inland cities around Brisbane. This will likely mean extra structural requirements such as extra rail for installs.

## Determine the Terrain Category

It requires to determine the right terrain category to ensure the installation meets the maximum interface spacing specified in the engineering certificate.

In 1170.2-2021, Terrain category 1.5 was removed and Terrain category 2.5 was added. See the definitions below.

Terrain Category 1 (TC1) – Very exposed open terrain with very few or no obstructions, and all water surfaces (e.g. flat, treeless, poorly grassed plains; open ocean, rivers, canals, bays and lakes).

Terrain Category 2 (TC2) – Open terrain, including grassland, with well-scattered obstructions having heights generally from 1.5 m to 5 m, with no more than two obstructions per hectare (e.g. farmland and cleared subdivisions with isolated trees and uncut grass).

Terrain Category 2.5 (TC2.5) – Terrain with some trees or isolated obstructions, terrain in developing outer urban areas with scattered houses, or larger acreage developments with more than two and less than 10 buildings per hectare.

Terrain Category 3 (TC3) – Terrain with numerous closely spaced obstructions having heights generally from 3 m to 10 m. The minimum density of obstructions shall be at least the equivalent of 10 house-size obstructions per hectare (e.g. suburban housing, light industrial estates or dense forests).

Terrain Category 4 (TC4) – Terrain with numerous large, high (10 m to 30 m tall) and closely spaced constructions, such as large city centres and well-developed industrial complexes.

If your installation site is not at TC 2, 2.5 or 3, please contact Clenergy to obtain a project specific engineering certificate to support your installation.

## Determine the Height of the Installation Site

This document provides sufficient information for the PVezRack® SolarRoof system installation up to heights of 30 meters. If your installation site is more than 30 meters high please contact Clenergy to obtain project specific engineering certificate to support your installation.

## Determine Roof slope

The PVezRack® SolarRoof system can be used for roof slopes up to 10°. Please verify that the Installation site roof slope is between 0° and 10°.

### Determine the Installation Area of Roof

There is an important change on the installation area of roof based on the certification letter (refer to Note 1), which is installation shall be only on top of the purlins with a maximum tolerance of 150mm. See the sketch below.

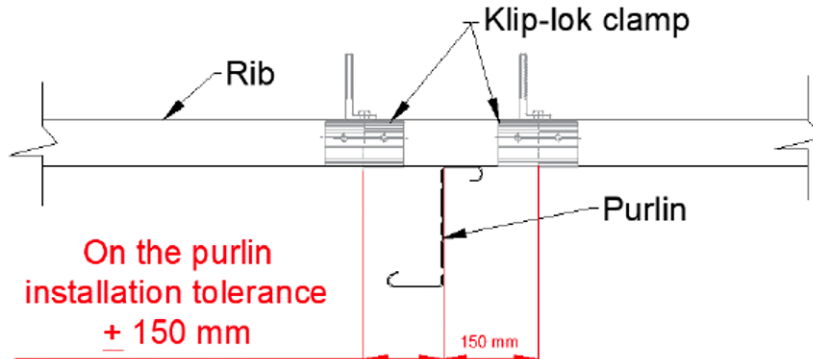

For the general installation area of roof, please refer to the notes 6, 24-26 of Certification Letter to determine it based on building height, length and width. Please be also aware at certain building conditions there is an Exclusion Zone for flush installation, which is the minimum distance between PV solar panel and roof edge of "2s", where "s" is the gap between the underside of the panel and the roof surface.

Please refer to note 2 in Certification Letter for roof sheet specific exclusion of installation of the Klip-lok interfaces. For example, for Metroll Metlok 700 roof sheet, Lapjoints installation is excluded.

If your installation does not meet the requirements above, please contact Clenergy to request a project specific engineering certificate to support your installation.

### Determine the Maximum Rail Support Spacing

Please refer to the Certification Letter and Interface Spacing Table. If a project specific Certification Letter has been provided, please refer to the support spacing in this letter.

### Verify Maximum Rail End Overhang





Rail end overhang is defined as the distance from last interface to the end of panel. Maximum rail end overhang is 40% of the last interface installed spacing. For example, if the max interface spacing in generic engineering certificate is 1800 mm and installed spacing of last interface is 1500 mm, the maximum rail end overhang is 600 mm. Please refer to note 16 of certification letter for the details by sketch.

### Determine the Clamping Zone of PV Modules

Please refer to the installation manual of the PV module manufacturer for the clamping zone info.

# Tools and Components





## Tools

				
<p><b>Screw Driver</b> (for M8 Hexagon Socket Screw)</p>	<p><b>String</b></p>	<p><b>Torque Spanner</b></p>	<p><b>5m Tape</b></p>	<p><b>String &amp; Marker Pen</b></p>

## Components

				
<p><b>ER-EC-ST</b> End Clamp</p>	<p><b>ER-IC-ST</b> Inter Clamp</p>	<p><b>C-U/30/46-G</b> Akashi Clamp</p>	<p><b>C-U/30/46</b> Akashi Clamp</p>	<p><b>ER-EC-DU35/40</b> End Clamp, Dual 35 or 40mm</p>
				
<p><b>ER-EC-DU40/46</b> End Clamp, Dual 40 or 46mm</p>	<p><b>ER-R-ECO</b> ECO Rail</p>	<p><b>ER-SP-ECO</b> Splice for ECO Rail</p>		

## Components

				
<p><b>CRC-R/ECO</b> Cross Connector Clamp of ECO-Rail</p>	<p><b>K-CRC/PT</b> Cross Connector Clamp and Plate Kit</p>	<p><b>ER-I-05</b> Tin Interface</p>	<p><b>ER-I-05/CM</b> Tin Interface with Click Module</p>	<p><b>ER-I-05A/EZC/ECO</b> Tin Interface A with ezClick connection</p>

## Applicable Klip-lok Interfaces

				
<p><b>ER-I-34</b> Brooklyn Klip-lok Interface</p>	<p><b>ER-I-09</b> Klip-lok Interface 700</p>	<p><b>ER-I-32/AU</b> Klip-lok Interface 406</p>	<p><b>ER-I-29/AU</b> SolarRoof, Klip-lok Interface for longline 305</p>	<p><b>ER-I-34/CRC</b> Brooklyn Klip-lok Interface pre-assembly with Cross Connector Clamp</p>
				
<p><b>ER-I-34/05A/EZC</b> Brooklyn Klip-lok Interface pre-assembly with Tin Interface A with ezClick module</p>	<p><b>ER-I-34/CRC/PT</b> Brooklyn Klip-lok Clamp pre-assembly with Cross Connector Clamp and Plate Kit</p>	<p><b>ER-I-09/CRC</b> Klip lok Interface 400-700HS, pre-assembly with Cross Connector Clamp</p>	<p><b>ER-I-32/CRC</b> Klip-lok Interface 406, pre-assembly with Cross Connector Clamp</p>	

# System Overview

## Overview of Klip-lok Interface

With Cross Connector Clamp (use Brooklyn Klip-lok Interface as an example)

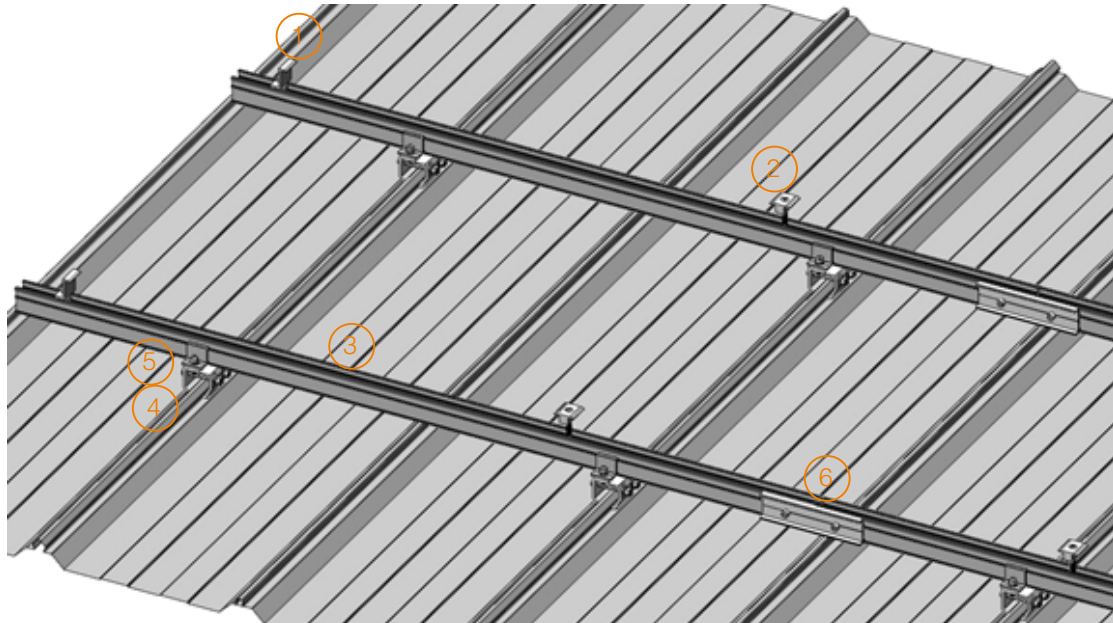

- 1. End Clamp    2. Inter Clamp    3. ECO Rail    4. Brooklyn Klip-lok Interface    5. Cross Connector Clamp
- 6. Splice for ECO Rail

With Tin Interface (use Brooklyn Klip-lok Interface as an example)

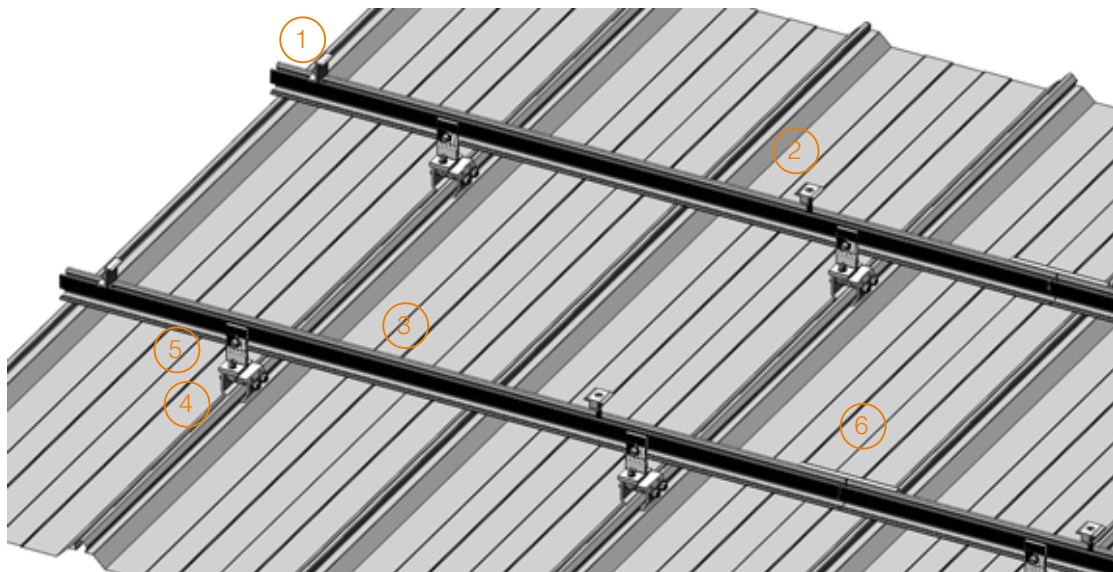

- 1. End Clamp    2. Inter Clamp    3. ECO Rail    4. Brooklyn Klip-lok Interface    5. Tin Interface
- 6. Splice for ECO Rail

## Precautions during Stainless Steel Fastener Installation

Improper operation may lead to deadlock of Nuts and Bolts. The steps below should be applied to stainless steel nut and bolt assembly to reduce this risk.

### General installation instructions

- (1) Apply force to fasteners in the direction of thread
- (2) Apply force uniformly, to maintain the required torque
- (3) Professional tools and tool belts are recommended
- (4) In some cases, fasteners could be seized over time. As an option, if want to avoid galling or seizing of thread, apply lubricant (grease or 40# engine oil) to fasteners prior to tightening.

### Safe Torques

Please refer to safe torques defined in this guide as shown in the figures below. In case power tools are required, Clenergy recommends the use of low speed only. High speed and impact drivers increase the risk of bolt galling (deadlock) If deadlock occurs and you need to cut fasteners, ensure that there is no load on the fastener before you cut it. Avoid damaging the anodized or galvanized surfaces.

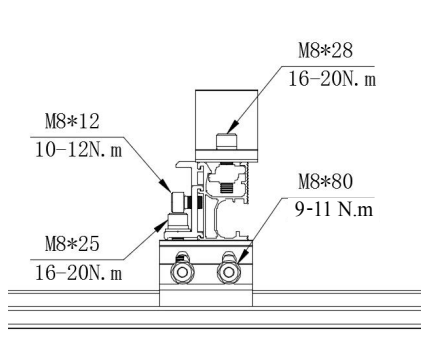

ER-I-34 with Cross Connector Clamp

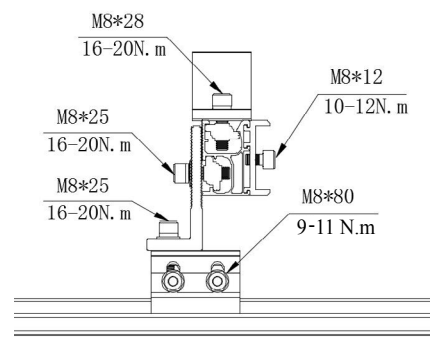

ER-I-34 with Tin Interface

**Note:**

When clamping Lysaght LongLine 305 with ER-I-34, the torque shall be 13-17 N.m.

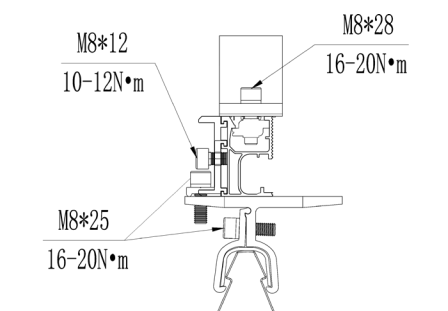

ER-I-09, ER-I-29/AU or ER-I-32/AU with Cross Connector Clamp

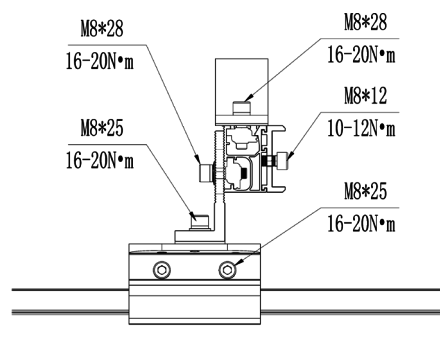

ER-I-09, ER-I-29/AU or ER-I-32/AU with Tin Interface

## Installation Dimensions

All drawings and dimensions in this Installation Guide are a generic reference only. The PVezRack® SolarRoof is to be optimized to suit specific conditions for each project and should be documented in a construction drawing.

Major components of the PVezRack® SolarRoof may be provided in section sizes and lengths varying from those shown in this guide. The installation process detailed in this instruction guide remains the same regardless of changes in component size.

If you need to do any on-site modifications or alteration of the system please provide marked up drawings/sketches for Clenergy's review, prior to modification, for comment and approval.

# Installation Instructions

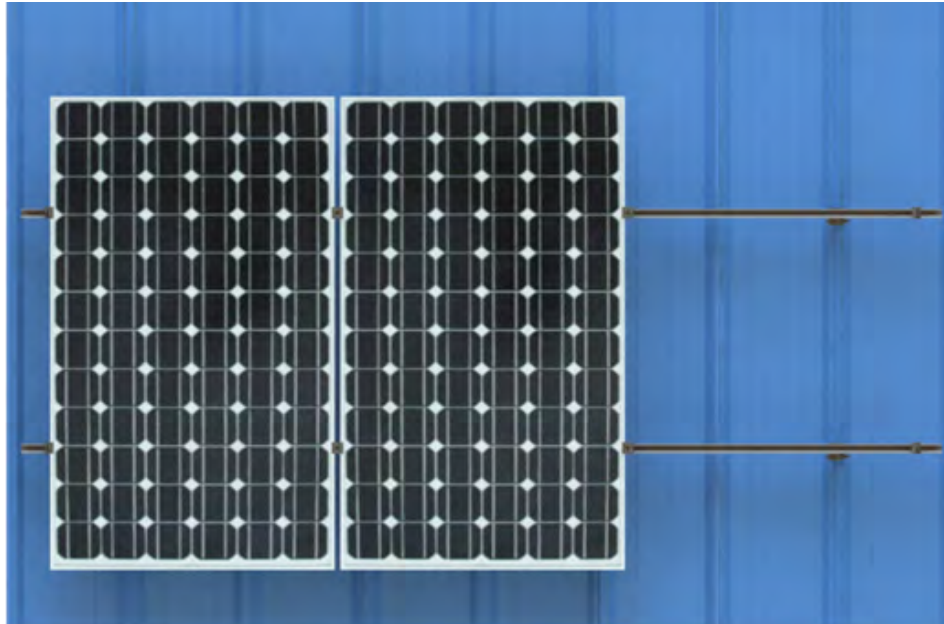

- Assess the number of modules in the vertical direction using the module height plus at least 18mm between modules (please check the installation manual of the solar module manufacturer);
- Assess the Number of modules in the horizontal direction using the module width plus 18 mm (20 mm if using Universal Clamps) between the modules. Note: The standard end clamp will also add 20 mm (except for dual end clamps) on each side to the space required;
- Assess the horizontal spacing of the Roof Hooks;
- Assess the vertical spacing of the Roof Hooks = approx. 1/2 to 3/4 of module height;
- Always check the installation manual of the PV-Module you use in order to determine the allowed fixing points on the module frame.

## Brooklyn Klip-lok Interface Installation

According to your plan, fix the Brooklyn Klip-lok Interface on the ribs of metal sheet. Fasten the bolts of the Brooklyn Klip-lok Interface within 9-11 N.m (except Lysaght LongLine 305) after adjusted properly.

### Recommended Installation Method

Step 1. Set the low-range torque wrench value to 11 N.m. Hold a nut with a spanner and fasten a bolt to 11 N.m with the Torque Wrench.

Step 2. Hold the other nut and fasten the other bolt to 11 N.m. with the torque wrench.

### Check Fasteners Torque Method

Set the torque wrench value to 9 N.m, and check fasteners torque in the fastening direction. If one or another

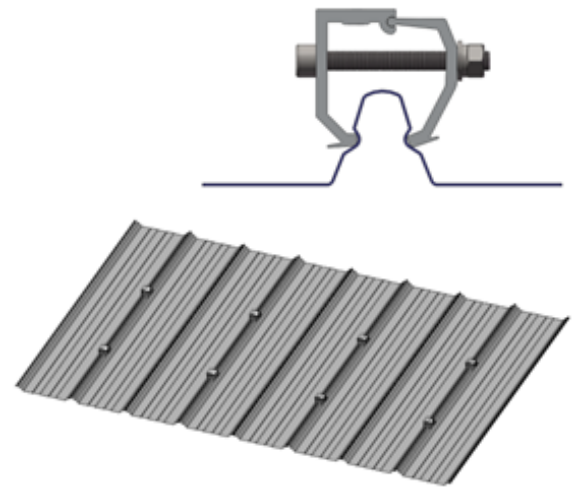

## Installation Cross Connector Clamp of ECO-Rail & Tin Interface Installation

When using Cross Connector Clamp of ECO-Rail, fix the Cross Connector Clamp of ECO-Rail on the top face (side hole only) of the Brooklyn Klip-lok Interface. Fasten the bolt of the Cross Connector Clamp slightly before installing the ECO-Rail. Please note the rails can run perpendicular to ribs only.

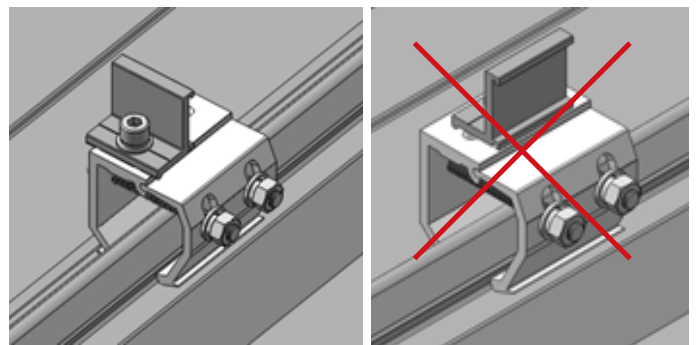

Cross Connector Clamp and Plate Kit (K-CRC/PT) provides an option of running rails parallel to ribs. Place the Cross Connector Clamp Plate aligning on the central hole of the Brooklyn Klip-lok Clamp.

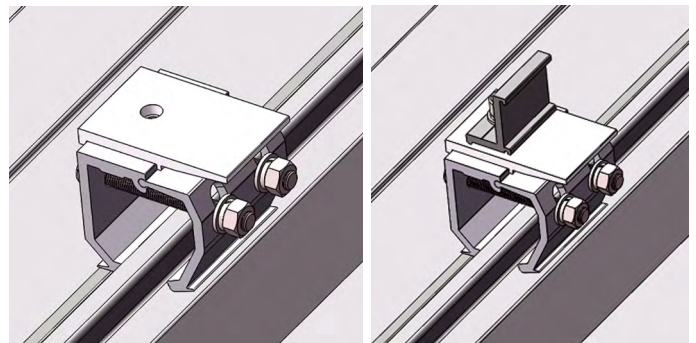

Fix the Cross Connector Clamp of ECO-Rail on the the Plate. Fasten the bolt of the Cross Connector Clamp slightly before installing the ECO-Rail.

When using Tin Interface, fix the Tin Interface on the top face of the Brooklyn Klip-lok Interface, fasten the Tin Interface and the Brooklyn Klip-lok Interface using M8 bolt within 16-20N.m after adjusted properly.

### Note:

Pre-fitted rubber pad (if applicable) at the bottom surface of Tin Interface shall be taken off to avoid rubber aging effect on fastener torque.

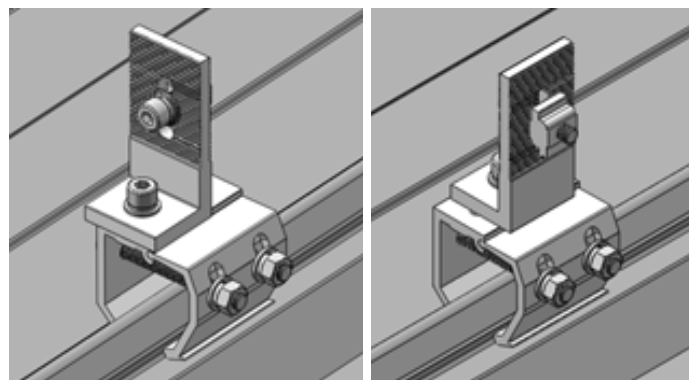

## Other Klip-lok Interface Installation

According to the installation plan, after determining the position of the first Klip-lok Interface, fix it on the rib of tin roof and fasten lightly.

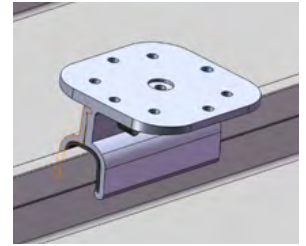

Recommended torque for M8 bolts is 16-20N·m.

Fix the other Klip-lok Interfaces on the tin roof with the string as shown in the figure on the right.

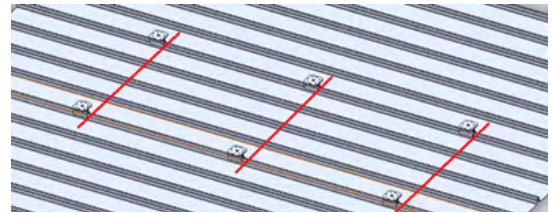

## Cross Connector Clamp of ECO-Rail & Tin Interface Installation

When using the Klip-lok Interface and Cross Connector Clamp with ECO- Rail, please install according to the steps below:

Fix all Cross Connector Clamp of ECO-Rail in the middle hole or side hole of the Klip-lok Interface, do not fasten tightly as shown in the figure on the right.

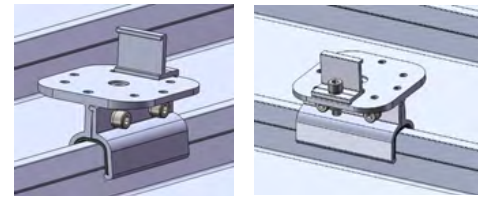

When using the Klip-lok Interface and Tin Interface with ECO-Rail, please install according to the steps below:

Install all the Tin Interfaces on the middle hole of Klip-lok Interface, do not fasten tightly as shown in the figure on the right.

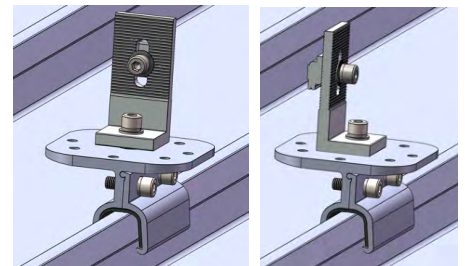

**Note:**

Pre-fitted rubber pad (if applicable) at the bottom surface of Tin Interface shall be taken off to avoid rubber aging effect on fastener torque.

## Rail Installation

To connect several rails together, slide half of the splice into the rear side of the rail. Fasten the first M8 Bolt using an Allen key, and slide the next rail into the splice. Tighten the second M8 Bolt using an Allen key.

Splice provides the electrical connection between the 2 rails through the pressure bolts. This eliminates the need of using 2 earthing lugs.

Recommended torque is 10 ~12 Nm.

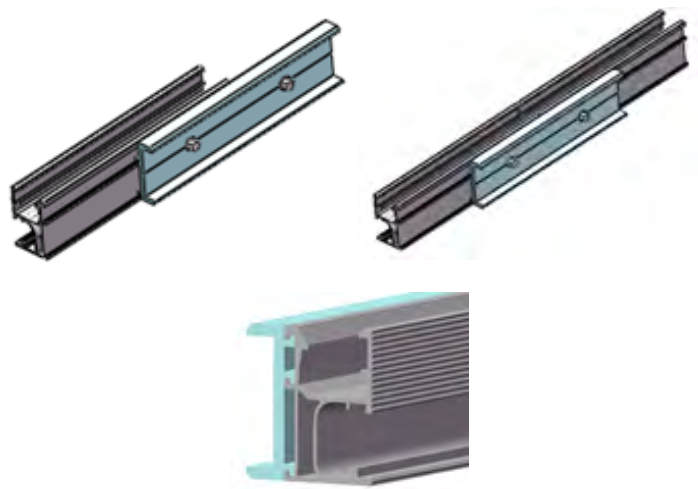

If the rails consist of different lengths, always begin with the shortest piece.

When using Rail Clamp, place the ECO-Rail on the Klip-lok Interface, uplift the Rail Clamp and click it into the side channels of the ECO-Rail as shown in the right figure. Fasten the Rail Clamp within 16-20 N.m after the Rail is positioned properly.

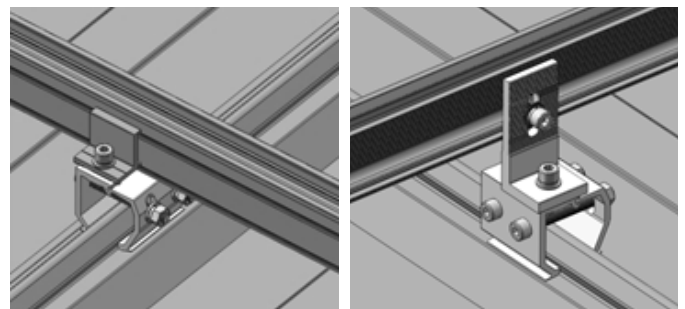

When using Tin Interface, fix the ECO-Rail and Tin Interface as shown in the right figure and then fasten within 16-20 N.m. after Rail is positioned properly.

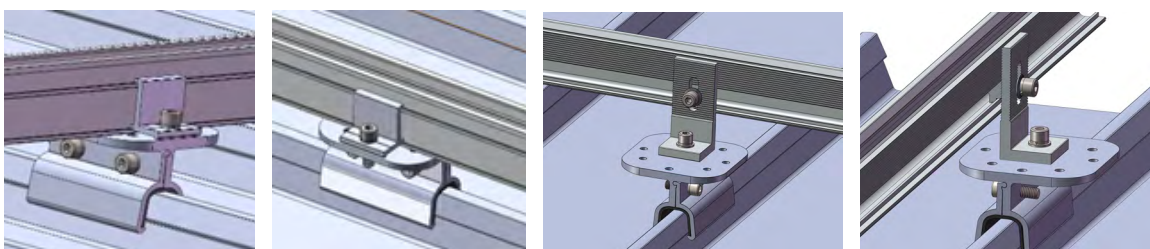

## PV Module Installation

- 1) Please refer [PVezRack® Grounding System](#) for PV modules clamps and grounding lugs installations.
- 2) The installers must ensure panel clamps are installed flush mounted to the panel frame and apply correct torque value of clamp fastener as shown in section "**Safe Torques (Page 13)**".

# Certification



**CIVIL & STRUCTURAL ENGINEERS**  
RESIDENTIAL - INDUSTRIAL - COMMERCIAL - PRODUCT DEVELOPMENT

info@mwengineering.melbourne  
Phone: 1300 MWENG-0 (1300 69364-0)  
www.mwengineering.melbourne  
ABN 37 605 815 585

18 July 2023

Clenergy Australia  
1/10 Duerdin Street  
Clayton, VIC 3168

## CERTIFICATION LETTER

Clenergy PV-ezRack Solar Roof Certification – TC2, 2.5, 3 – Wind Region A, B1, B2, C, D. Internal REF: **00606**. Project REF: **CL-343-S-REV-8**.

MW Engineering Melbourne, being Structural Engineers within the meaning of Australian regulations, have calculated the maximum spacings for the PV ez-Rack rail system for the following conditions:

- **Wind Loads to AS 1170.2-2021**
  - o **Wind Terrain Category 2, 2.5 and 3**
  - o **Wind average recurrence of 200 years**
  - o **Wind Region A, B1, B2, C, D**
- **Solar panel length up to 2.4m**
- **Solar panel width up to 1.2m**

Attached are the tables showing the spacings according to Wind Region, roof pitch, and building height.

The values shown on these tables will be valid unless an amendment is issued on any of the following codes:

- |                                   |                           |
|-----------------------------------|---------------------------|
| - AS/NZS 1170.0- 2002 AMDT 4-2016 | <b>General Principles</b> |
| - AS/NZS 1170.1- 2002 AMDT 4-2016 | <b>Imposed Loadings</b>   |
| - AS/NZS 1170.2- 2021             | <b>Wind Loadings</b>      |
| - AS/NZS 1664.1- 1997 AMDT 1:1999 | <b>Aluminium Code</b>     |

Should you have any queries, do not hesitate to contact us.

Best Regards,



Alberto Escobar  
Civil/Structural Engineer  
**BEng MIEAust NER**  
PE 0003615  
RPEQ 18759  
BDC 3134  
BPB (NT) 262228ES  
BSP (TAS) 845530344  
[info@mwengineering.melbourne](mailto:info@mwengineering.melbourne)

July 2023

STRUCTURAL DESIGN CERTIFICATION



# Klip-lok Flush Interface spacing tables

Standard: AS/NZS 1170.2:2021

Terrain Category: 2, 2.5 & 3

**Client: Clenergy Australia**

**REF: 00606**

**Date: JULY 2023**

**Copyright:** The concepts and information contained in this document are the property of MW Engineering Melbourne. Use or copying of this document in whole or in part without the written permission of MW Engineering Melbourne constitutes an infringement in copyright.

**Limitation:** This report has been prepared for the exclusive use of Clenergy Australia, and is subject to and issued in connection with the provisions of the agreement between MW Engineering Melbourne and Clenergy Australia. MW Engineering Melbourne accepts no liability or responsibility whatsoever for any use of or reliance upon this report by any third party other than Clenergy's clients.

Clenergy reference: CL- 343-S- REV 8

**Project: PV-ezRack SolarRoof Klip-lok flush interface spacing tables**

**Australian Standards**

**AS/NZS 1170.0:2002 (R2016)**

**General Principles**

**AS/NZS 1170.1:2002 (R2016)**

**Imposed Loadings**

**AS/NZS 1170.2:2021**

**Wind Loadings**

**AS/NZS 1664.1:1997-Amdt 1:1999**

**Aluminium**

**Rail type: ECO - Rails**

**Wind Terrain Category: 2, 2.5 & 3**

**Wind average recurrence: 200 years**

This engineering document was designed to cater for most common installation scenarios defined with an importance level 2 (200 years wind average recurrence) such as residential shed or garage, small - isolated warehouses and farm sheds, residential carports, and one or double storey dwelling. If the project conditions do not fit on the above criteria, please contact Clenergy for an assessment.

From 1 May 2023 installers must follow AS/NZS 1170.2:2021 only.

**Designed: AE**

**Date: JULY 2023**

**Disclaimer: From the date of publication onwards, any amendment made to any of the above-mentioned Standards will make this report outdated and a new one will have to be released, unless the amendment has no implications on this certificate**

## PV-ezRack SolarRoof Interface spacing table for

### LYSAGHT KLIP-LOK 700 CLASSIC

Type of Rail	ER-R-ECO (refer to Note 10 for other compatible rails)
Type of Interface	ER-I-09 and ER-I-34
Solar Panel Dimension	2 m x 1 m (Refer to Note 26 for other panel sizes)

ROOF ANGLE	$0^\circ < \alpha \leq 10^\circ$									
TC	3									
BUILDING HEIGHT (m)	$\leq 5$		$5 < H \leq 10$		$10 < H \leq 15$		$15 < H \leq 20$		$20 < H \leq 30$	
	UW&DW	Central	UW&DW	Central	UW&DW	Central	UW&DW	Central	UW&DW	Central
A	1970	2160	1970	2160	1871	2047	1723	1963	1507	1874
B1	1495	1947	1495	1947	1287	1849	1146	1665	1005	1456
B2	1346	1878	1346	1878	1160	1686	1033	1498	907	1311
C	960	1389	960	1389	829	1196	740	1066	651	935
D	679	977	679	977	588	844	525	753	463	662

ROOF ANGLE	$0^\circ < \alpha \leq 10^\circ$									
TC	2.5									
BUILDING HEIGHT (m)	$\leq 5$		$5 < H \leq 10$		$10 < H \leq 15$		$15 < H \leq 20$		$20 < H \leq 30$	
	UW&DW	Central	UW&DW	Central	UW&DW	Central	UW&DW	Central	UW&DW	Central
A	1903	2082	1828	2004	1609	1917	1475	1860	1330	1795
B1	1351	1881	1213	1765	1072	1555	984	1425	890	1285
B2	1217	1772	1094	1588	967	1400	889	1284	803	1158
C	869	1256	783	1128	693	997	638	916	577	828
D	616	885	555	796	492	705	453	649	411	587

ROOF ANGLE	$0^\circ < \alpha \leq 10^\circ$									
TC	2									
BUILDING HEIGHT (m)	$\leq 5$		$5 < H \leq 10$		$10 < H \leq 15$		$15 < H \leq 20$		$20 < H \leq 30$	
	UW&DW	Central	UW&DW	Central	UW&DW	Central	UW&DW	Central	UW&DW	Central
A	1841	2012	1507	1874	1357	1808	1277	1771	1182	1650
B1	1227	1786	1005	1456	907	1311	855	1235	793	1143
B2	1107	1606	907	1311	819	1182	773	1113	716	1031
C	792	1141	651	935	588	845	555	796	515	738
D	562	806	463	662	419	599	395	565	367	524

## PV-ezRack SolarRoof Interface spacing table for

### LYSAGHT KLIP-LOK 700 HI-STRENGTH

Type of Rail                      ER-R-ECO (refer to Note 10 for other compatible rails)

Type of Interface                ER-I-09 and ER-I-34

Solar Panel Dimension        2 m x 1 m (Refer to Note 26 for other panel sizes)

ROOF ANGLE	$0^\circ < \alpha \leq 10^\circ$									
TC	3									
BUILDING HEIGHT (m)	$\leq 5$		5<H≤10		10<H≤15		15<H≤20		20<H≤30	
	UW&DW	Central	UW&DW	Central	UW&DW	Central	UW&DW	Central	UW&DW	Central
A	1916	2160	1916	2160	1641	2047	1456	1963	1273	1789
B1	1263	1849	1263	1849	1087	1584	968	1406	849	1230
B2	1137	1659	1137	1659	980	1424	873	1265	766	1108
C	811	1173	811	1173	700	1011	625	900	550	790
D	574	825	574	825	497	713	444	636	391	559

ROOF ANGLE	$0^\circ < \alpha \leq 10^\circ$									
TC	2.5									
BUILDING HEIGHT (m)	$\leq 5$		5<H≤10		10<H≤15		15<H≤20		20<H≤30	
	UW&DW	Central	UW&DW	Central	UW&DW	Central	UW&DW	Central	UW&DW	Central
A	1725	2082	1544	2004	1360	1916	1246	1750	1123	1572
B1	1141	1666	1025	1491	906	1314	832	1204	751	1086
B2	1028	1497	924	1341	817	1183	751	1085	679	979
C	734	1061	661	953	586	842	539	774	487	699
D	520	747	469	673	416	596	383	548	347	496

ROOF ANGLE	$0^\circ < \alpha \leq 10^\circ$									
TC	2									
BUILDING HEIGHT (m)	$\leq 5$		5<H≤10		10<H≤15		15<H≤20		20<H≤30	
	UW&DW	Central	UW&DW	Central	UW&DW	Central	UW&DW	Central	UW&DW	Central
A	1563	2012	1273	1789	1146	1606	1079	1510	999	1394
B1	1037	1509	849	1230	766	1108	723	1043	670	966
B2	935	1357	766	1108	692	998	653	941	605	871
C	669	964	550	790	497	713	469	673	435	624
D	474	680	391	559	354	506	334	477	310	443

## PV ez-Rack SolarRoof Interface spacing table for

### LYSAGHT KLIP-LOK 406

Type of Rail	ER-R-ECO (refer to Note 10 for other compatible rails)
Type of Interface	ER-I-32/AU and ER-I-34
Solar Panel Dimension	2 m x 1 m (Refer to Note 26 for other panel sizes)

ROOF ANGLE	$0^\circ < \alpha \leq 10^\circ$									
TC	3									
BUILDING HEIGHT (m)	$\leq 5$		$5 < H \leq 10$		$10 < H \leq 15$		$15 < H \leq 20$		$20 < H \leq 30$	
	UW&DW	Central	UW&DW	Central	UW&DW	Central	UW&DW	Central	UW&DW	Central
A	1970	2160	1970	2160	1871	2047	1798	1963	1719	1874
B1	1715	1947	1715	1947	1624	1849	1446	1777	1269	1700
B2	1656	1878	1656	1878	1464	1785	1304	1716	1145	1642
C	1211	1673	1211	1673	1047	1510	934	1345	822	1181
D	857	1233	857	1233	742	1065	663	950	584	836

ROOF ANGLE	$0^\circ < \alpha \leq 10^\circ$									
TC	2.5									
BUILDING HEIGHT (m)	$\leq 5$		$5 < H \leq 10$		$10 < H \leq 15$		$15 < H \leq 20$		$20 < H \leq 30$	
	UW&DW	Central	UW&DW	Central	UW&DW	Central	UW&DW	Central	UW&DW	Central
A	1903	2082	1834	2004	1757	1917	1707	1860	1649	1795
B1	1658	1881	1531	1812	1353	1737	1243	1688	1123	1622
B2	1537	1815	1381	1749	1221	1678	1122	1620	1014	1462
C	1097	1585	988	1424	875	1259	805	1156	728	1045
D	778	1117	701	1005	622	890	572	819	518	741

ROOF ANGLE	$0^\circ < \alpha \leq 10^\circ$									
TC	2									
BUILDING HEIGHT (m)	$\leq 5$		$5 < H \leq 10$		$10 < H \leq 15$		$15 < H \leq 20$		$20 < H \leq 30$	
	UW&DW	Central	UW&DW	Central	UW&DW	Central	UW&DW	Central	UW&DW	Central
A	1841	2012	1719	1874	1660	1808	1612	1771	1492	1725
B1	1549	1820	1269	1700	1145	1642	1080	1559	1001	1443
B2	1397	1756	1145	1642	1034	1492	975	1405	904	1301
C	999	1440	822	1181	743	1066	701	1005	650	932
D	709	1017	584	836	528	756	499	713	463	662

## PV ez-Rack SolarRoof Interface spacing table for **STRAMIT SPEED DECK ULTRA**

Type of Rail                      ER-R-ECO (refer to Note 10 for other compatible rails)  
Type of Interface                ER-I-09 and ER-I-34  
Solar Panel Dimension        2 m x 1 m (Refer to Note 26 for other panel sizes)

ROOF ANGLE	$0^\circ < \alpha \leq 10^\circ$									
TC	3									
BUILDING HEIGHT (m)	$\leq 5$		5<H≤10		10<H≤15		15<H≤20		20<H≤30	
	UW&DW	Central	UW&DW	Central	UW&DW	Central	UW&DW	Central	UW&DW	Central
A	1970	2160	1970	2160	1871	2047	1798	1963	1719	1874
B1	1715	1947	1715	1947	1527	1849	1359	1777	1193	1700
B2	1597	1878	1597	1878	1376	1785	1226	1716	1076	1556
C	1138	1647	1138	1647	984	1419	878	1264	772	1110
D	806	1159	806	1159	697	1001	623	893	549	786

ROOF ANGLE	$0^\circ < \alpha \leq 10^\circ$									
TC	2.5									
BUILDING HEIGHT (m)	$\leq 5$		5<H≤10		10<H≤15		15<H≤20		20<H≤30	
	UW&DW	Central	UW&DW	Central	UW&DW	Central	UW&DW	Central	UW&DW	Central
A	1903	2082	1834	2004	1757	1917	1707	1860	1577	1795
B1	1603	1881	1439	1812	1272	1737	1168	1688	1055	1525
B2	1444	1815	1298	1749	1147	1661	1054	1523	953	1374
C	1031	1490	928	1338	822	1183	756	1087	685	982
D	731	1050	659	945	584	837	538	770	487	696

ROOF ANGLE	$0^\circ < \alpha \leq 10^\circ$									
TC	2									
BUILDING HEIGHT (m)	$\leq 5$		5<H≤10		10<H≤15		15<H≤20		20<H≤30	
	UW&DW	Central	UW&DW	Central	UW&DW	Central	UW&DW	Central	UW&DW	Central
A	1841	2012	1719	1874	1609	1808	1515	1771	1403	1725
B1	1456	1820	1193	1700	1076	1556	1015	1465	941	1356
B2	1313	1756	1076	1556	972	1402	917	1321	850	1223
C	939	1354	772	1110	698	1002	659	945	611	876
D	666	956	549	786	497	710	469	670	435	622

## PV ez-Rack SolarRoof Interface spacing table for

### FIELDERS KINGKLIP 700

Type of Rail	ER-R-ECO (refer to Note 10 for other compatible rails)
Type of Interface	ER-I-09 and ER-I-34
Solar Panel Dimension	2 m x 1 m (Refer to Note 26 for other panel sizes)

ROOF ANGLE	$0^\circ < \alpha \leq 10^\circ$									
TC	3									
BUILDING HEIGHT (m)	$\leq 5$		$5 < H \leq 10$		$10 < H \leq 15$		$15 < H \leq 20$		$20 < H \leq 30$	
	UW&DW	Central	UW&DW	Central	UW&DW	Central	UW&DW	Central	UW&DW	Central
A	1212	1733	1212	1733	1038	1474	921	1301	805	1132
B1	799	1170	799	1170	688	1002	612	889	537	778
B2	719	1050	719	1050	620	901	552	800	485	701
C	513	742	513	742	443	639	395	569	348	500
D	363	522	363	522	314	451	281	402	247	354

ROOF ANGLE	$0^\circ < \alpha \leq 10^\circ$									
TC	2.5									
BUILDING HEIGHT (m)	$\leq 5$		$5 < H \leq 10$		$10 < H \leq 15$		$15 < H \leq 20$		$20 < H \leq 30$	
	UW&DW	Central	UW&DW	Central	UW&DW	Central	UW&DW	Central	UW&DW	Central
A	1091	1553	977	1383	860	1212	788	1107	710	995
B1	722	1054	648	943	573	831	526	762	475	687
B2	650	947	584	848	517	748	475	686	429	619
C	464	671	418	603	370	533	341	489	308	442
D	329	473	297	425	263	377	242	346	219	314

ROOF ANGLE	$0^\circ < \alpha \leq 10^\circ$									
TC	2									
BUILDING HEIGHT (m)	$\leq 5$		$5 < H \leq 10$		$10 < H \leq 15$		$15 < H \leq 20$		$20 < H \leq 30$	
	UW&DW	Central	UW&DW	Central	UW&DW	Central	UW&DW	Central	UW&DW	Central
A	988	1401	805	1132	725	1016	683	955	632	882
B1	656	955	537	778	485	701	457	660	424	611
B2	591	858	485	701	438	632	413	595	383	551
C	423	610	348	500	314	451	297	425	275	394
D	300	430	247	354	224	320	211	302	-	280

## PV ez-Rack SolarRoof Interface spacing table for

### STRATCO TOPDECK 700

Type of Rail                      ER-R-ECO (refer to Note 10 for other compatible rails)

Type of Interface                ER-I-09 and ER-I-34

Solar Panel Dimension         2 m x 1 m (Refer to Note 26 for other panel sizes)

ROOF ANGLE	$0^\circ < \alpha \leq 10^\circ$									
TC	3									
BUILDING HEIGHT (m)	$\leq 5$		5<H≤10		10<H≤15		15<H≤20		20<H≤30	
	UW&DW	Central	UW&DW	Central	UW&DW	Central	UW&DW	Central	UW&DW	Central
A	1173	1677	1173	1677	1004	1427	891	1259	779	1095
B1	773	1132	773	1132	665	970	592	861	520	753
B2	696	1016	696	1016	600	872	534	774	469	678
C	496	718	496	718	429	619	382	551	336	484
D	351	505	351	505	304	436	271	389	239	342

ROOF ANGLE	$0^\circ < \alpha \leq 10^\circ$									
TC	2.5									
BUILDING HEIGHT (m)	$\leq 5$		5<H≤10		10<H≤15		15<H≤20		20<H≤30	
	UW&DW	Central	UW&DW	Central	UW&DW	Central	UW&DW	Central	UW&DW	Central
A	1056	1503	945	1338	832	1173	763	1071	687	963
B1	699	1020	627	913	554	804	509	737	460	664
B2	629	916	566	821	500	724	459	664	415	599
C	449	649	405	583	358	516	330	474	298	428
D	318	457	287	412	254	365	234	335	212	303

ROOF ANGLE	$0^\circ < \alpha \leq 10^\circ$									
TC	2									
BUILDING HEIGHT (m)	$\leq 5$		5<H≤10		10<H≤15		15<H≤20		20<H≤30	
	UW&DW	Central	UW&DW	Central	UW&DW	Central	UW&DW	Central	UW&DW	Central
A	957	1356	779	1095	702	983	661	924	611	853
B1	635	924	520	753	469	678	442	639	410	591
B2	572	831	469	678	424	611	399	576	370	533
C	409	590	336	484	304	437	287	412	266	382
D	290	416	239	342	216	309	204	292	-	271

## PV ez-Rack SolarRoof Interface spacing table for

### LYSAGHT LONGLINE 305

Type of Rail	ER-R-ECO (refer to Note 10 for other compatible rails)
Type of Interface	ER-I-29/AU and ER-I-34 (Refer to Note 4 for ER-I-34 reduction factors)
Solar Panel Dimension	2 m x 1 m (Refer to Note 26 for other panel sizes)

ROOF ANGLE	$0^\circ < \alpha \leq 10^\circ$									
TC	3									
BUILDING HEIGHT (m)	$\leq 5$		$5 < H \leq 10$		$10 < H \leq 15$		$15 < H \leq 20$		$20 < H \leq 30$	
	UW&DW	Central	UW&DW	Central	UW&DW	Central	UW&DW	Central	UW&DW	Central
A	1814	2160	1814	2160	1554	2047	1378	1948	1205	1694
B1	1196	1751	1196	1751	1029	1500	916	1332	804	1165
B2	1077	1571	1077	1571	928	1349	827	1198	726	1049
C	768	1111	768	1111	663	957	592	852	521	748
D	543	781	543	781	470	675	420	602	370	530

ROOF ANGLE	$0^\circ < \alpha \leq 10^\circ$									
TC	2.5									
BUILDING HEIGHT (m)	$\leq 5$		$5 < H \leq 10$		$10 < H \leq 15$		$15 < H \leq 20$		$20 < H \leq 30$	
	UW&DW	Central	UW&DW	Central	UW&DW	Central	UW&DW	Central	UW&DW	Central
A	1634	2082	1462	2004	1287	1814	1180	1658	1064	1490
B1	1081	1577	970	1412	857	1244	787	1140	712	1028
B2	974	1417	875	1270	774	1120	711	1027	643	927
C	695	1004	626	902	554	798	510	733	462	662
D	493	708	444	637	394	564	363	519	328	470

ROOF ANGLE	$0^\circ < \alpha \leq 10^\circ$									
TC	2									
BUILDING HEIGHT (m)	$\leq 5$		$5 < H \leq 10$		$10 < H \leq 15$		$15 < H \leq 20$		$20 < H \leq 30$	
	UW&DW	Central	UW&DW	Central	UW&DW	Central	UW&DW	Central	UW&DW	Central
A	1480	2012	1205	1694	1085	1521	1022	1429	946	1320
B1	982	1429	804	1165	726	1049	684	988	634	914
B2	885	1285	726	1049	655	945	618	891	573	825
C	633	913	521	748	471	676	444	637	412	591
D	449	644	370	530	335	479	316	452	293	419

## PV ez-Rack SolarRoof Interface spacing table for

### METROLL METLOK 700

Type of Rail	ER-R-ECO (refer to Note 10 for other compatible rails)
Type of Interface	ER-I-09 and ER-I-34
Solar Panel Dimension	2 m x 1 m (Refer to Note 26 for other panel sizes)

ROOF ANGLE	$0^\circ < \alpha \leq 10^\circ$									
TC	3									
BUILDING HEIGHT (m)	$\leq 5$		$5 < H \leq 10$		$10 < H \leq 15$		$15 < H \leq 20$		$20 < H \leq 30$	
	UW&DW	Central	UW&DW	Central	UW&DW	Central	UW&DW	Central	UW&DW	Central
A	1970	2160	1970	2160	1871	2047	1798	1963	1719	1874
B1	1715	1947	1715	1947	1631	1849	1569	1777	1470	1700
B2	1656	1878	1656	1878	1576	1785	1511	1716	1327	1642
C	1403	1673	1403	1673	1213	1592	1082	1532	952	1368
D	993	1428	993	1428	860	1234	768	1101	677	968

ROOF ANGLE	$0^\circ < \alpha \leq 10^\circ$									
TC	2.5									
BUILDING HEIGHT (m)	$\leq 5$		$5 < H \leq 10$		$10 < H \leq 15$		$15 < H \leq 20$		$20 < H \leq 30$	
	UW&DW	Central	UW&DW	Central	UW&DW	Central	UW&DW	Central	UW&DW	Central
A	1903	2082	1834	2004	1757	1917	1707	1860	1649	1795
B1	1658	1881	1599	1812	1535	1737	1440	1688	1301	1630
B2	1601	1815	1545	1749	1414	1678	1300	1630	1175	1575
C	1271	1618	1144	1561	1014	1458	932	1340	844	1211
D	901	1294	812	1165	720	1032	663	949	601	859

ROOF ANGLE	$0^\circ < \alpha \leq 10^\circ$									
TC	2									
BUILDING HEIGHT (m)	$\leq 5$		$5 < H \leq 10$		$10 < H \leq 15$		$15 < H \leq 20$		$20 < H \leq 30$	
	UW&DW	Central	UW&DW	Central	UW&DW	Central	UW&DW	Central	UW&DW	Central
A	1841	2012	1719	1874	1660	1808	1627	1771	1586	1725
B1	1606	1820	1470	1700	1327	1642	1251	1609	1160	1568
B2	1551	1756	1327	1642	1198	1586	1130	1554	1048	1508
C	1158	1567	952	1368	861	1235	812	1165	754	1080
D	821	1178	677	968	612	876	578	826	537	767

## PV ez-Rack SolarRoof Interface spacing table for

### STRAMIT SPEED DECK 500

Type of Rail	ER-R-ECO (refer to Note 10 for other compatible rails)
Type of Interface	ER-I-09 and ER-I-34
Solar Panel Dimension	2 m x 1 m (Refer to Note 26 for other panel sizes)

ROOF ANGLE	$0^\circ < \alpha \leq 10^\circ$									
TC	3									
BUILDING HEIGHT (m)	$\leq 5$		$5 < H \leq 10$		$10 < H \leq 15$		$15 < H \leq 20$		$20 < H \leq 30$	
	UW&DW	Central	UW&DW	Central	UW&DW	Central	UW&DW	Central	UW&DW	Central
A	1634	2160	1634	2160	1400	1987	1242	1754	1086	1526
B1	1077	1577	1077	1577	927	1352	826	1199	724	1049
B2	970	1416	970	1416	836	1215	745	1079	654	945
C	691	1001	691	1001	597	862	533	768	469	674
D	489	704	489	704	424	608	378	542	333	477

ROOF ANGLE	$0^\circ < \alpha \leq 10^\circ$									
TC	2.5									
BUILDING HEIGHT (m)	$\leq 5$		$5 < H \leq 10$		$10 < H \leq 15$		$15 < H \leq 20$		$20 < H \leq 30$	
	UW&DW	Central	UW&DW	Central	UW&DW	Central	UW&DW	Central	UW&DW	Central
A	1472	2082	1317	1865	1160	1634	1063	1493	958	1342
B1	974	1421	874	1272	772	1120	709	1027	641	926
B2	877	1277	788	1144	697	1009	640	925	579	835
C	626	905	564	813	499	719	459	660	416	597
D	444	638	400	574	355	508	327	467	296	423

ROOF ANGLE	$0^\circ < \alpha \leq 10^\circ$									
TC	2									
BUILDING HEIGHT (m)	$\leq 5$		$5 < H \leq 10$		$10 < H \leq 15$		$15 < H \leq 20$		$20 < H \leq 30$	
	UW&DW	Central	UW&DW	Central	UW&DW	Central	UW&DW	Central	UW&DW	Central
A	1333	1888	1086	1526	978	1370	921	1287	852	1189
B1	884	1287	724	1049	654	945	616	890	571	824
B2	797	1158	654	945	590	852	557	802	516	743
C	570	822	469	674	424	609	400	574	371	532
D	405	580	333	477	302	431	285	407	264	378

## PV ez-Rack SolarRoof Interface spacing table for

### REV-KLIP 700

Type of Rail                      ER-R-ECO (refer to Note 10 for other compatible rails)  
 Type of Interface                ER-I-34  
 Solar Panel Dimension         2 m x 1 m (Refer to Note 26 for other panel sizes)

ROOF ANGLE	$0^\circ < \alpha \leq 10^\circ$									
TC	3									
BUILDING HEIGHT (m)	$\leq 5$		5<H≤10		10<H≤15		15<H≤20		20<H≤30	
	UW&DW	Central	UW&DW	Central	UW&DW	Central	UW&DW	Central	UW&DW	Central
A	1712	2160	1712	2160	1467	2047	1301	1838	1138	1599
B1	1129	1653	1129	1653	972	1416	865	1257	759	1099
B2	1016	1483	1016	1483	876	1273	780	1131	685	990
C	725	1048	725	1048	626	903	559	805	491	706
D	513	737	513	737	444	637	397	568	349	500

ROOF ANGLE	$0^\circ < \alpha \leq 10^\circ$									
TC	2.5									
BUILDING HEIGHT (m)	$\leq 5$		5<H≤10		10<H≤15		15<H≤20		20<H≤30	
	UW&DW	Central	UW&DW	Central	UW&DW	Central	UW&DW	Central	UW&DW	Central
A	1542	2082	1380	1955	1215	1713	1114	1565	1004	1406
B1	1020	1489	916	1333	809	1174	743	1076	672	970
B2	919	1338	826	1199	730	1057	671	969	607	875
C	656	948	591	852	523	753	481	692	436	625
D	465	668	419	601	372	533	342	490	310	443

ROOF ANGLE	$0^\circ < \alpha \leq 10^\circ$									
TC	2									
BUILDING HEIGHT (m)	$\leq 5$		5<H≤10		10<H≤15		15<H≤20		20<H≤30	
	UW&DW	Central	UW&DW	Central	UW&DW	Central	UW&DW	Central	UW&DW	Central
A	1397	1979	1138	1599	1024	1435	965	1350	893	1246
B1	927	1349	759	1099	685	990	646	932	599	863
B2	836	1213	685	990	619	892	583	841	541	779
C	598	862	491	706	444	638	419	601	389	557
D	424	608	349	500	316	452	298	426	277	396

## PV ez-Rack SolarRoof Interface spacing table for

### METROLL METLOK 500

Type of Rail	ER-R-ECO (refer to Note 10 for other compatible rails)
Type of Interface	ER-I-34
Solar Panel Dimension	2 m x 1 m (Refer to Note 26 for other panel sizes)

ROOF ANGLE	$0^\circ < \alpha \leq 10^\circ$									
TC	3									
BUILDING HEIGHT (m)	$\leq 5$		$5 < H \leq 10$		$10 < H \leq 15$		$15 < H \leq 20$		$20 < H \leq 30$	
	UW&DW	Central	UW&DW	Central	UW&DW	Central	UW&DW	Central	UW&DW	Central
A	1118	1599	1118	1599	957	1359	849	1200	743	1044
B1	737	1079	737	1079	634	925	565	821	495	718
B2	663	968	663	968	572	831	509	738	447	646
C	473	684	473	684	409	590	365	525	321	461
D	335	481	335	481	290	416	259	371	228	326

ROOF ANGLE	$0^\circ < \alpha \leq 10^\circ$									
TC	2.5									
BUILDING HEIGHT (m)	$\leq 5$		$5 < H \leq 10$		$10 < H \leq 15$		$15 < H \leq 20$		$20 < H \leq 30$	
	UW&DW	Central	UW&DW	Central	UW&DW	Central	UW&DW	Central	UW&DW	Central
A	1007	1432	901	1276	793	1118	727	1021	655	918
B1	666	972	598	870	528	766	485	703	438	633
B2	600	873	539	783	477	690	438	633	396	571
C	428	619	386	556	342	491	314	451	284	408
D	304	436	274	392	243	348	223	320	202	289

ROOF ANGLE	$0^\circ < \alpha \leq 10^\circ$									
TC	2									
BUILDING HEIGHT (m)	$\leq 5$		$5 < H \leq 10$		$10 < H \leq 15$		$15 < H \leq 20$		$20 < H \leq 30$	
	UW&DW	Central	UW&DW	Central	UW&DW	Central	UW&DW	Central	UW&DW	Central
A	912	1292	743	1044	669	937	630	881	583	813
B1	605	881	495	718	447	646	422	609	391	563
B2	545	792	447	646	404	583	381	549	353	508
C	390	562	321	461	290	416	274	392	254	364
D	277	397	228	326	206	295	-	278	-	258

## PV ez-Rack SolarRoof Interface spacing table for

### STEELINE STEEL-RIB 500 (ST28)

Type of Rail                      ER-R-ECO (refer to Note 10 for other compatible rails)  
 Type of Interface                ER-I-34  
 Solar Panel Dimension         2 m x 1 m (Refer to Note 26 for other panel sizes)

ROOF ANGLE	0° <math>\alpha \le 10^\circ</math>									
TC	3									
BUILDING HEIGHT (m)	<math>\le 5</math>		5<math><H \le 10</math>		10<math><H \le 15</math>		15<math><H \le 20</math>		20<math><H \le 30</math>	
	UW&DW	Central	UW&DW	Central	UW&DW	Central	UW&DW	Central	UW&DW	Central
A	1470	2102	1470	2102	1259	1788	1117	1578	977	1373
B1	969	1419	969	1419	834	1216	743	1079	652	944
B2	872	1273	872	1273	752	1093	670	971	588	850
C	622	900	622	900	537	775	480	691	422	606
D	440	633	440	633	381	547	340	488	300	429

ROOF ANGLE	0° <math>\alpha \le 10^\circ</math>									
TC	2.5									
BUILDING HEIGHT (m)	<math>\le 5</math>		5<math><H \le 10</math>		10<math><H \le 15</math>		15<math><H \le 20</math>		20<math><H \le 30</math>	
	UW&DW	Central	UW&DW	Central	UW&DW	Central	UW&DW	Central	UW&DW	Central
A	1324	1884	1185	1678	1043	1470	956	1343	862	1207
B1	876	1278	786	1144	695	1008	638	924	576	833
B2	789	1148	709	1029	627	907	576	832	521	751
C	563	814	507	731	449	646	413	594	374	537
D	399	573	360	516	319	457	294	420	266	380

ROOF ANGLE	0° <math>\alpha \le 10^\circ</math>									
TC	2									
BUILDING HEIGHT (m)	<math>\le 5</math>		5<math><H \le 10</math>		10<math><H \le 15</math>		15<math><H \le 20</math>		20<math><H \le 30</math>	
	UW&DW	Central	UW&DW	Central	UW&DW	Central	UW&DW	Central	UW&DW	Central
A	1199	1699	977	1373	879	1233	828	1159	766	1069
B1	796	1158	652	944	588	850	554	800	514	741
B2	717	1041	588	850	531	766	501	722	464	668
C	513	740	422	606	381	547	360	516	334	478
D	364	522	300	429	271	388	256	366	238	340

## PV ez-Rack SolarRoof Interface spacing table for

### REVOLUTION MAXLINE 340

Type of Rail                    ER-R-ECO (refer to Note 10 for other compatible rails)  
 Type of Interface            ER-I-34  
 Solar Panel Dimension      2 m x 1 m (Refer to Note 26 for other panel sizes)

ROOF ANGLE	$0^\circ < \alpha \leq 10^\circ$									
TC	3									
BUILDING HEIGHT (m)	$\leq 5$		$5 < H \leq 10$		$10 < H \leq 15$		$15 < H \leq 20$		$20 < H \leq 30$	
	UW&DW	Central	UW&DW	Central	UW&DW	Central	UW&DW	Central	UW&DW	Central
A	1970	2160	1970	2160	1871	2047	1798	1963	1719	1874
B1	1715	1947	1715	1947	1631	1849	1493	1777	1310	1700
B2	1656	1878	1656	1878	1512	1785	1347	1716	1183	1642
C	1251	1673	1251	1673	1081	1560	965	1389	848	1219
D	885	1273	885	1273	766	1100	685	982	603	863

ROOF ANGLE	$0^\circ < \alpha \leq 10^\circ$									
TC	2.5									
BUILDING HEIGHT (m)	$\leq 5$		$5 < H \leq 10$		$10 < H \leq 15$		$15 < H \leq 20$		$20 < H \leq 30$	
	UW&DW	Central	UW&DW	Central	UW&DW	Central	UW&DW	Central	UW&DW	Central
A	1903	2082	1834	2004	1757	1917	1707	1860	1649	1795
B1	1658	1881	1581	1812	1397	1737	1283	1688	1160	1630
B2	1587	1815	1426	1749	1261	1678	1158	1630	1047	1510
C	1133	1618	1020	1471	904	1300	831	1194	752	1079
D	803	1153	724	1038	642	920	591	846	535	765

ROOF ANGLE	$0^\circ < \alpha \leq 10^\circ$									
TC	2									
BUILDING HEIGHT (m)	$\leq 5$		$5 < H \leq 10$		$10 < H \leq 15$		$15 < H \leq 20$		$20 < H \leq 30$	
	UW&DW	Central	UW&DW	Central	UW&DW	Central	UW&DW	Central	UW&DW	Central
A	1841	2012	1719	1874	1660	1808	1627	1771	1541	1725
B1	1600	1820	1310	1700	1183	1642	1115	1609	1034	1490
B2	1443	1756	1183	1642	1068	1541	1007	1451	934	1344
C	1032	1488	848	1219	767	1101	724	1038	672	963
D	732	1050	603	863	546	780	515	736	478	683

## PV ez-Rack SolarRoof Interface spacing table for

### STEELINE LOKDECK 680

Type of Rail                      ER-R-ECO (refer to Note 10 for other compatible rails)  
 Type of Interface                ER-I-34  
 Solar Panel Dimension           2 m x 1 m (Refer to Note 26 for other panel sizes)

ROOF ANGLE	$0^\circ < \alpha \leq 10^\circ$									
TC	3									
BUILDING HEIGHT (m)	$\leq 5$		$5 < H \leq 10$		$10 < H \leq 15$		$15 < H \leq 20$		$20 < H \leq 30$	
	UW&DW	Central	UW&DW	Central	UW&DW	Central	UW&DW	Central	UW&DW	Central
A	938	1342	938	1342	803	1140	713	1007	623	876
B1	618	905	618	905	532	776	474	688	416	602
B2	557	813	557	813	480	697	427	619	375	542
C	397	574	397	574	343	495	306	441	269	387
D	281	404	281	404	243	349	217	311	-4	274

ROOF ANGLE	$0^\circ < \alpha \leq 10^\circ$									
TC	2.5									
BUILDING HEIGHT (m)	$\leq 5$		$5 < H \leq 10$		$10 < H \leq 15$		$15 < H \leq 20$		$20 < H \leq 30$	
	UW&DW	Central	UW&DW	Central	UW&DW	Central	UW&DW	Central	UW&DW	Central
A	845	1202	756	1070	666	938	610	857	550	770
B1	559	816	502	730	443	643	407	589	368	531
B2	503	733	452	657	400	579	367	531	332	479
C	359	519	324	466	287	412	264	379	238	342
D	255	366	229	329	203	292	-4	268	-4	243

ROOF ANGLE	$0^\circ < \alpha \leq 10^\circ$									
TC	2									
BUILDING HEIGHT (m)	$\leq 5$		$5 < H \leq 10$		$10 < H \leq 15$		$15 < H \leq 20$		$20 < H \leq 30$	
	UW&DW	Central	UW&DW	Central	UW&DW	Central	UW&DW	Central	UW&DW	Central
A	765	1084	623	876	561	786	528	739	489	683
B1	508	739	416	602	375	542	354	511	328	473
B2	458	664	375	542	339	489	319	460	296	426
C	327	472	269	387	243	349	229	329	213	305
D	232	333	-	274	-	247	-	233	-	217

## PV ez-Rack SolarRoof Interface spacing table for

### STEELINE APEX STEEL APDECK 700

Type of Rail                      ER-R-ECO (refer to Note 10 for other compatible rails)  
 Type of Interface              ER-I-09  
 Solar Panel Dimension        2 m x 1 m (Refer to Note 26 for other panel sizes)

ROOF ANGLE	$0^\circ < \alpha \leq 10^\circ$									
TC	3									
BUILDING HEIGHT (m)	$\leq 5$		$5 < H \leq 10$		$10 < H \leq 15$		$15 < H \leq 20$		$20 < H \leq 30$	
	UW&DW	Central	UW&DW	Central	UW&DW	Central	UW&DW	Central	UW&DW	Central
A	1634	2160	1634	2160	1400	1987	1242	1754	1086	1526
B1	1077	1577	1077	1577	927	1352	826	1199	724	1049
B2	970	1416	970	1416	836	1215	745	1079	654	945
C	691	1001	691	1001	597	862	533	768	469	674
D	489	704	489	704	424	608	378	542	333	477

ROOF ANGLE	$0^\circ < \alpha \leq 10^\circ$									
TC	3									
BUILDING HEIGHT (m)	$\leq 5$		$5 < H \leq 10$		$10 < H \leq 15$		$15 < H \leq 20$		$20 < H \leq 30$	
	UW&DW	Central	UW&DW	Central	UW&DW	Central	UW&DW	Central	UW&DW	Central
A	1472	2082	1317	1865	1160	1634	1063	1493	958	1342
B1	974	1421	874	1272	772	1120	709	1027	641	926
B2	877	1277	788	1144	697	1009	640	925	579	835
C	626	905	564	813	499	719	459	660	416	597
D	444	638	400	574	355	508	327	467	296	423

ROOF ANGLE	$0^\circ < \alpha \leq 10^\circ$									
TC	3									
BUILDING HEIGHT (m)	$\leq 5$		$5 < H \leq 10$		$10 < H \leq 15$		$15 < H \leq 20$		$20 < H \leq 30$	
	UW&DW	Central	UW&DW	Central	UW&DW	Central	UW&DW	Central	UW&DW	Central
A	1333	1888	1086	1526	978	1370	921	1287	852	1189
B1	884	1287	724	1049	654	945	616	890	571	824
B2	797	1158	654	945	590	852	557	802	516	743
C	570	822	469	674	424	609	400	574	371	532
D	405	580	333	477	302	431	285	407	264	378

## General Notes

**Note 1.** This engineering document was designed to cater for most common PV installation scenarios however, it does not cater for all of them. Contact Clenergy if you are unable to comply with any of the installation specifications listed on this document.

**Note 2.** Installation to be done only on top of the purlins with a maximum tolerance of 150 mm.

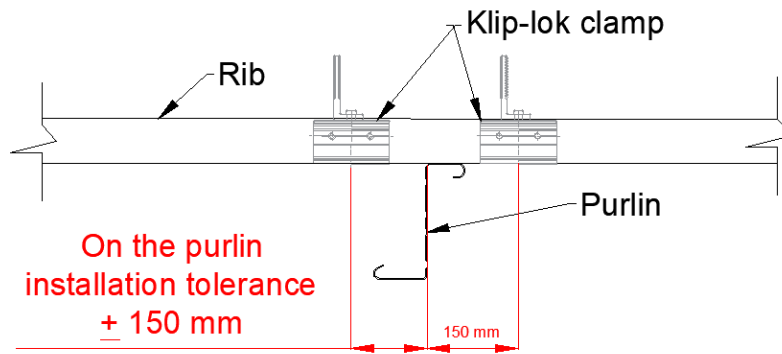

**Note 3.** Exclusion for installation of klip-lok clamps depending on the roof sheet type to be as per the following table.

Roof Sheet type	Exclusions	Test Report No.
Lysaght KLIP-LOK 700 Classic	N/A	MT-19/0633-A
Lysaght KLIP-LOK 700 Hi-Strength	N/A	MT-11/023
Lysaght KLIP-LOK 406	N/A	MT-17/001-A
Stramit Speed Deck Ultra	N/A	MT-11/023
Fielders Kingklip 700	N/A	MT-11/280
Stratco Topdeck 700	N/A	MT-17/001-B and MT-19/1007
Lysaght Longline 305	N/A	MT-13/133
Metroll Metlok 700	Exclude lapjoints	MT-19/0633-B
Stramit Speed Deck 500	N/A	MT-19/0762
Rev-klip 700	N/A	MT-19/1018-A
Metroll Metlok 500	Exclude lapjoints	7530/MJ
Steeline Steel-Rib 500	N/A	MT-19/1090-B
Revolution Maxline 340	N/A	MT-19/1018-B
Steeline Lokdeck 680	N/A	20-0028

Contact Clenergy for a project specific assessment if you cannot comply the above exclusions.

Refer to the below pictures to find clamp position, rib type and location on respective roof sheet.

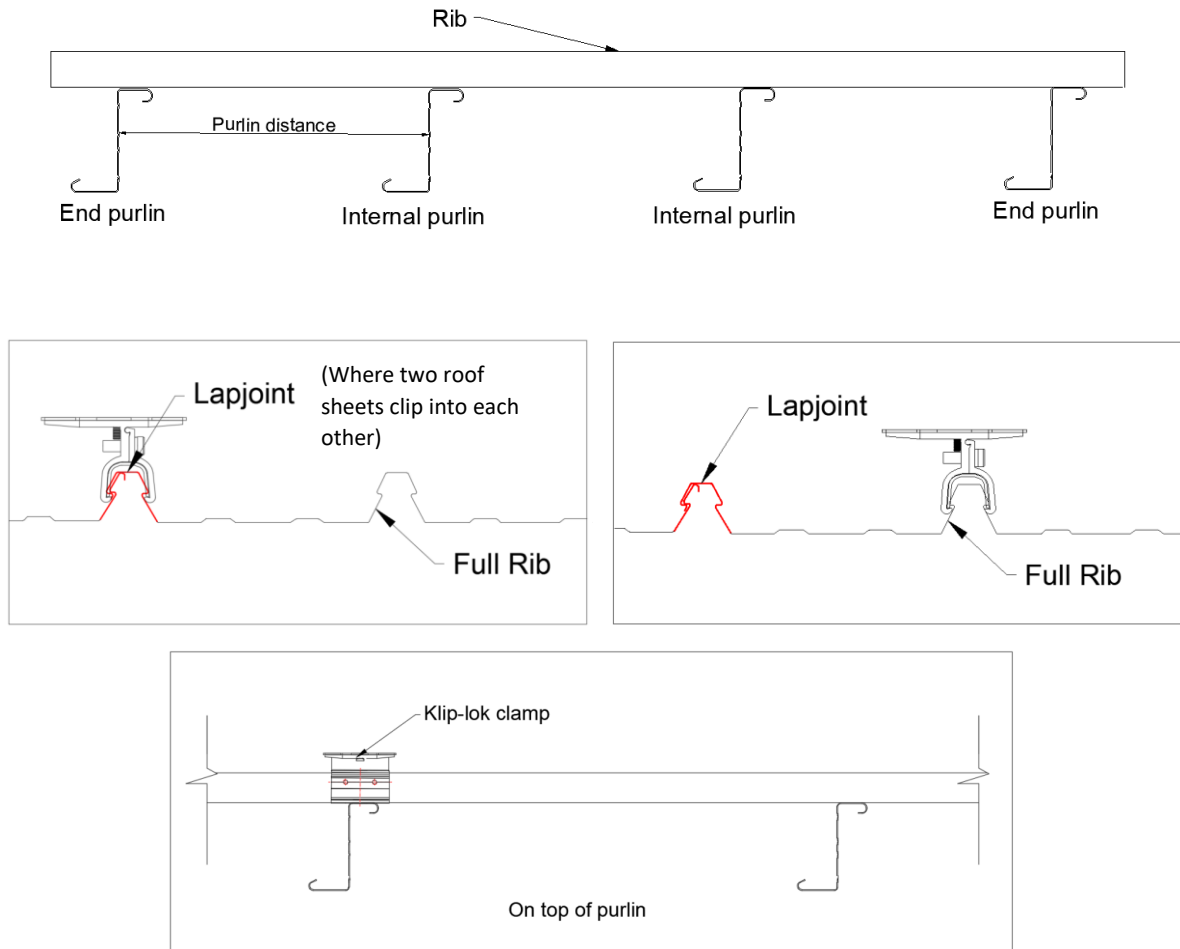

**Note 4.** Lysaght Longline 305 fixing spacings were calculated based on the capacity of Clenergy’s ER-I-29/AU clamp and the roof sheet. When using Clenergy’s ER-I-34 clamp, Longline 305 fixing spacings shall be reduced as follows:

Wind Region A	Wind Region B1	Wind Region B2& C
-80%	-80%	-70%

**Note 5.** Exclusion for installation of Clenergy’s ER-I-34 on Lysaght Longline 305 roof sheet to be as per the below table

Roof Sheet type	Exclusions	Test Report No.
Lysaght Longline 305	• Exclude lapjoints	MT- 20-0661

**Note 6.** Rails cannot run parallel to the ribs unless the applicable table spacings are equal or larger the purlin distance. Contact Clenergy if you are unable to comply with this condition or any of the installation specifications listed on this document.

**Note 7.** The spacing information in this document has been designed to be compliant with the capacity of the below items per roof area:

- Klip-lok clamp
- Roofing sheet

- Fixing clip between roofing sheet to purlin

Prior to carrying the PV installation, it is recommended to check that the roof sheet has been installed according to the manufacturers specifications and there are no missing clips.

Roof area is defined as a single surface that has no height variance.

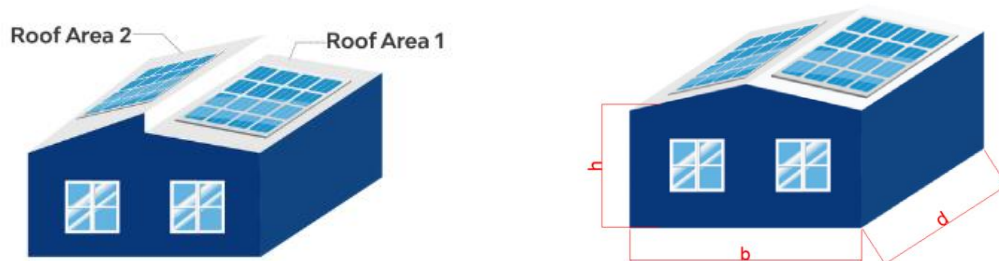

**Note 8.** This document does not cover the following:

- Building frame capacity
- Off the purlin installation

**Note 9.** This certificate only covers the assessment of the Clenergy PV mounting system, including the components listed on note 10. Assessment of the roof structure, PV panels and other fixings are to be checked by the installer/contractor.

**Note 10.** The following components are satisfied for use according to AS/NZS 1664.1:1997-Amdt 1:1999 and AS/NZS 1170.2:2021.

Components	Part No.	Description
ECO-Rail	ER-R-ECO/XXXX	ECO-Rail
Splice	ER-SP-ECO	PV-ezRack Splice for ECO-Rail
Australian Made Mill Finish ECO-Rail	R-ECO/XXXX/AUMF	PV-ezRack Australian Made Mill Finish ECO-Rail
ST-Rail	ER-R-STXXXX	Standard Rail
Splice	ER-SP-ST	PV-ezRack Splice for Standard Rail 200mm
Roof bracket	ER-I-09	Klip-lok bracket

Roof bracket	ER-I-09/100/45	Klip-lok bracket
Roof bracket	ER-I-29/AU	Klip-lok bracket
Roof bracket	ER-I-32/AU	Klip-lok bracket
Roof bracket	ER-I-34	Universal Klip-lok clamp
Inter Clamp	ER-IC-STXX	Inter Clamp = clamp + Z-Module + bolt
End Clamp	ER-EC-STXX	End Clamp = clamp + Z-Module + bolt
Security Inter Clamp	ER-IC-STXX/S	Security Inter Clamp
Security End Clamp	ER-EC-STXX/S	Security End Clamp
Clamp	C-U/30/46-G	Universal Clamp for Frame Height 30-46mm with Grounding Clip
Clamp Clamp	C-U/30/46-G C-U/30/46	Universal Clamp for Frame Height 30-46mm with Grounding Clip Universal Clamp for Frame Height 30-46mm
Clamp End Clamp	C-U/30/46 ER-EC-DU35/40	Universal Clamp for Frame Height 30-46mm End Clamp dual 35 or 40mm
End Clamp End Clamp	ER-EC-DU35/40 ER-EC-DU40/46	End Clamp dual 35 or 40mm End Clamp dual 40 or 46mm
End Clamp Cross Connection Clamp	ER-EC-DU40/46 CRC-R/ECO CRC-R/ECO-ZBW	End Clamp dual 40 or 46mm Cross Connection Clamp
Cross Connection Clamp Plate	K-CRC/PT	Cross Connection Clamp Plate
Interface	ER-I-05	Tin Interface

Interface Interface	ER-I-05 ER-I-05/BA	Tin Interface Tin Interface Black
Interface Interface	ER-I-05/BA ER-I-05/CM	Tin Interface Black Tin Interface with click module
Interface Interface	ER-I-05/CM ER-I-05A/EZC/ECO	Tin Interface with click module ezClick connection for ECO-Rail
Interface Interface	ER-I-05A/EZC/ECO ER-I-05/C5	ezClick connection for ECO-Rail  Tin Interface with C5 rated Screw
End Clamp (*)	EC-FL/GE/XX/XX	End Clamp for Frameless Module (glued EPDM)
End Clamp (*) Inter Clamp (*)	EC-FL/GE/XX/XX IC-FL/GE/XX/XX	End Clamp for Frameless Module (glued EPDM) Inter Clamp for Frameless Module (glued EPDM)
Inter Clamp (*) End Clamp (*)	IC-FL/GE/XX/XX ER-EC-FL/XX/XX	Inter Clamp for Frameless Module (glued EPDM) End Clamp for Frameless Module
End Clamp (*) Inter Clamp (*)	ER-EC-FL/XX/XX ER-IC-FL/XX/XX	End Clamp for Frameless Module Inter Clamp for Frameless Module
Inter Clamp (*) ECO-Rail Black	ER-IC-FL/XX/XX ER-R-ECO/XXXX/BA	Inter Clamp for Frameless Module ECO-Rail Black
Inter Clamp (*) ECO-Rail Black ECO-Rail Black Splice ECO-Rail Black	ER-IC-FL/XX/XX ER-R-ECO/XXXX/BA ER-R-ECO/XXXX/BA ER-SP-ECO/BA	Inter Clamp for Frameless Module ECO-Rail Black ECO-Rail Black Splice ECO-Rail Black
ECO-Rail Black Splice ECO-Rail Black Splice ECO-Rail Black Mid Clamp XX Black	ER-R-ECO/XXXX/BA ER-SP-ECO/BA ER-SP-ECO/BA ER-IC-STXXB	ECO-Rail Black Splice ECO-Rail Black Splice ECO-Rail Black Inter Clamp XX Black
Splice ECO-Rail Black Mid Clamp XX Black Mid Clamp XX Black End Clamp XX Black	ER-SP-ECO/BA ER-IC-STXXB ER-IC-STXXB ER-EC-STXXB	Splice ECO-Rail Black Inter Clamp XX Black Inter Clamp XX Black End Clamp XX Black
Mid Clamp XX Black End Clamp XX Black End Clamp XX Black Black Universal Clamp	ER-IC-STXXB ER-EC-STXXB ER-EC-STXXB C-U/30/46/BA	Inter Clamp XX Black End Clamp XX Black End Clamp XX Black Black Universal Clamp

End Clamp XX Black Black Universal Clamp Black Universal Clamp  Black Universal Clamp	ER-EC-STXXB C-U/30/46/BA C-U/30/46/BA C-U/30/46-G/BA	End Clamp XX Black Black Universal Clamp Black Universal Clamp  Black Universal Clamp with grounding clip
Black Universal Clamp  Black Universal Clamp  Black Universal Clamp  Roof bracket	C-U/30/46/BA C-U/30/46-G/BA C-U/30/46-G/BA ER-I-34/CRC	Black Universal Clamp  Black Universal Clamp with grounding clip  Black Universal Clamp with grounding clip  Universal Klip-lok Bracket Pre- assembly with Cross Connection Clamp
Black Universal Clamp  Roof bracket Roof bracket	C-U/30/46-G/BA ER-I-34/CRC ER-I-34/05A/EZC	Black Universal Clamp with grounding clip Universal Klip-lok Bracket Pre- assembly with Cross Connection Clamp Universal Klip-lok Bracket Pre- assembly with Tin Interface
Roof bracket	ER-I-34/CRC/BA	Black Universal Klip-lok Bracket Pre- assembly with Cross Connection Clamp
Roof bracket	ER-I-34/05A/EZC/BA	Black Universal Klip-lok Bracket Pre- assembly with Tin Interface

(\*) Subject to the panel manufacturer's installation guide.

**Note 11.** For Terrain Category (TC) definition, please refer to clause 4.2.1 of AS/NZS 1170.2:2021.

**Note 12.** Wind Direction Multiplier (Md) taken as 1.0. Refer to clause 3.3 of AS/NZS 1170.2:2021 for more information.

**Note 13.** Shielding Multiplier (Ms) taken as 1.0. Refer to clause 4.3 of AS/NZS 1170.2:2021 for more information.

**Note 14.** Topographic Multiplier (Mt) taken as 1.0. Refer to clause 4.4 of AS/NZS 1170.2:2021 for more information. For topographic Multiplier (Mt) more than 1.0 (installations on a mountain, hilly or sloped terrain). The below table provides a reduction factor applied for topographic multipliers greater than 1 (installation on a slope, hill on mountain). To achieve a more accurate and cost-effective design, please contact Clenergy Engineering department.

Mt	A, B1, B2	
	U.W & D. W	Central
1	1	1
1.01	1.00	1.00
1.02	1.00	1.00
1.03	0.92	0.94
1.04	0.92	0.94
1.06	0.92	0.88
1.08	0.85	0.88
1.09	0.85	0.81
1.1	0.85	0.81
1.2	0.69	0.69
1.3	0.54	0.56
1.4	0.46	0.50
1.5	0.38	0.44

For installations located in Wind region C and D please contact Clenergy Engineering department.

**Note 15.** This certificate cannot be used if the site is located on a hill, ridge or escarpment. Contact Clenergy if the aforementioned condition is met on site.

**Note 16.** Clamping zone of the PV panels shall be according to the manufacturer’s specifications.

**Note 17.** Capacities checked and compared against testing data from Clenergy Australia and MTS (NATA certified).

**Note 18.** Rail overhang ends where the panel finishes and this should be less than 40% of the last installed interface spacing.

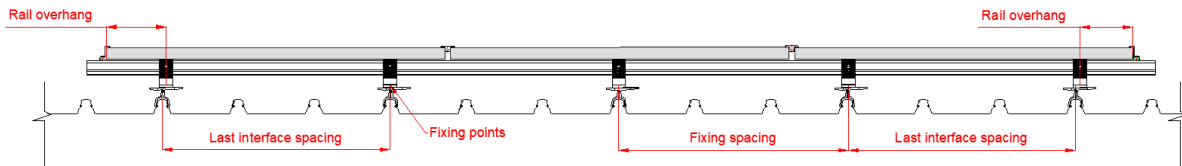

**Note 19.** ER-R-ECO rail splice can only be installed within 1/3 (maximum) of the fixing spacing (centre to centre) from the nearest interface when fixing spacing is over 1700 mm.

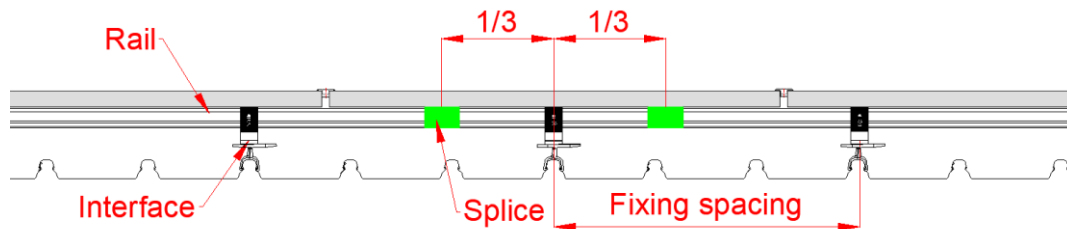

**Note 20.** ER-R-ECO rail splice cannot be installed on overhangs.

**Note 21.** From the date of publication onwards, any amendment made to any of the above-mentioned Standards will make this report outdated and a new one will have to be released, unless the amendment has no implications on this certificate.

**Note 22.** All components from Clenergy must be installed according to manufacturer's specification and the instructions shown in the relevant installation manual. Please check the Clenergy Australia website or contact them for access to the most recent installation manuals.

**Note 23.** Only hip and gable roofs installations are covered on this certificate. Contact Clenergy if you are planning to install on a different roof type such as curved, multi-span (pitched and saw-tooth), mansard, circular bins, silos, tanks, pitched free roofs, troughed free roofs, hypar free roofs, canopies, awnings and cantilevered roofs.

**Note 24.** No consideration has been taken on the effect of snow loads. In case the roof is located in a snow prone area, a project specific design must be completed.

**Note 25.** This Engineering report is based on 2 m x 1 m panels and two rails per panel. However, for different panel sizes a percentage increase or decrease can be applied on all interface spacings as shown on the following table.

Number of rails per panel	Panel length (mm)	Spacing +/-	
		W.R – A & B1	W.R – B2,C & D
2 rails	≤ 1700	+ 10 %	+ 12 %
3 rails	≤ 1700	+ 12 %	+ 18 %
4 rails	≤ 1700	+ 15 %	+ 20 %
2 rails	≤ 1800	+ 4 %	+ 7 %
3 rails	≤ 1800	+ 12 %	+ 18 %
4 rails	≤ 1800	+ 15 %	+ 20 %
2 rails	≤ 1900	0 %	+ 5 %
3 rails	≤ 1900	+ 10 %	+ 15 %
4 rails	≤ 1900	+ 12 %	+ 18 %
2 rails	≤ 2000	0 %	0 %
3 rails	≤ 2000	+ 10 %	+ 15 %
4 rails	≤ 2000	+ 12 %	+ 18 %
2 rails	≤ 2100	- 10 %	- 6 %
3 rails	≤ 2100	+ 10 %	+ 15 %
4 rails	≤ 2100	+ 12 %	+ 18 %
2 rails	≤ 2200	- 18 %	- 12 %
3 rails	≤ 2200	+ 7 %	+ 12 %
4 rails	≤ 2200	+ 12 %	+ 18 %
2 rails	≤ 2300	- 20 %	- 12 %
3 rails	≤ 2300	+ 5 %	+ 12 %
4 rails	≤ 2300	+ 10 %	+ 15 %
2 rails	≤ 2400	- 25 %	- 15 %
3;4 rails	≤ 2400	+ 5 ; 8 %	+ 10 ; +12%

**Note 26.** Panel width cannot exceed 1.20 m for any of the above panel length dimensions and panel weight cannot exceed 15 kg/m<sup>2</sup>.

**Note 27.** Conditions for flush mounted systems installed on flat and pitched roofs according to the D6 Appendix of the AS/NZS 1170.2:2021.

- Roof pitch to be between 1° and 30°.
- $h/d \leq 0.5$  and  $h/b \leq 0.5$ . Being  $h$ = height,  $b$ = width and  $d$ = length of the building as per the below picture.
- Gap between the underside of the panel and the roof to be no less than 50 mm and no more than 300 mm.
- Minimum distance from the edge of the roof to be "2s" where "s" is the gap between the underside of the panel and the roof.

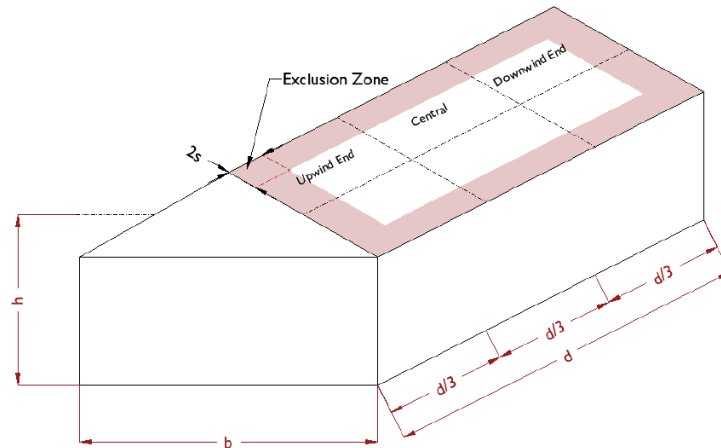

**Note 28.** Refer to the latest light commercial certificates when building parameters fall outside section B6 of the AS/NZS 1170.2:2021 standard.

**Note 29.** The more conservative outcome has to be used if one panel or panel row fall between two roof zones.

**Example**

- Wind Region A
- Terrain Category: 3
- Building height: 5m
- Roof pitch: less than 3°
- Roof Sheet: Lysaght Klip-lok 700 Classic
- Panel rail type: ER-R-ECO
- Panel rail orientation: perpendicular to purlins
- Purlin spacing: 1200 mm
- Panel dimension: 2 m x 1 m
- Fixing spacings as per below
  - o Upwind & Downwind: 1970 mm
  - o Central: 2160 mm

**Installation only feasible on top of the purlins, therefore:**

- o Upwind & Downwind: 1200 mm (with a maximum tolerance of 150 mm)
- o Central: 1200 mm (with a maximum tolerance of 150 mm)





## PV-ezRACK®

### Clenergy

3/10 Duerdin St  
Clayton VIC 3168  
Australia

Phone: +61 3 9239 8088  
Email: [sales@clenergy.com.au](mailto:sales@clenergy.com.au)  
Web: [www.clenergy.com.au](http://www.clenergy.com.au)

 @ClenergyGlobal / @ClenergyClub / ClenergyAUS  @Clenergy  @ClenergyClub  
 @Clenergy\_global  @Clenergy

A Clenergy Technologies Company